



Mathematics 2201 Final Examination

Teacher's Name: \_\_\_\_\_ Student's Name: \_\_\_\_\_

**Teacher Grading Sheet (PART I)**

- 1. \_\_\_\_\_
- 2. \_\_\_\_\_
- 3. \_\_\_\_\_
- 4. \_\_\_\_\_
- 5. \_\_\_\_\_
  
- 6. \_\_\_\_\_
- 7. \_\_\_\_\_
- 8. \_\_\_\_\_
- 9. \_\_\_\_\_
- 10. \_\_\_\_\_
  
- 11. \_\_\_\_\_
- 12. \_\_\_\_\_
- 13. \_\_\_\_\_
- 14. \_\_\_\_\_
- 15. \_\_\_\_\_
  
- 16. \_\_\_\_\_
- 17. \_\_\_\_\_
- 18. \_\_\_\_\_
- 19. \_\_\_\_\_
- 20. \_\_\_\_\_

- 21. \_\_\_\_\_
- 22. \_\_\_\_\_
- 23. \_\_\_\_\_
- 24. \_\_\_\_\_
- 25. \_\_\_\_\_
  
- 26. \_\_\_\_\_
- 27. \_\_\_\_\_
- 28. \_\_\_\_\_
- 29. \_\_\_\_\_
- 30. \_\_\_\_\_
  
- 31. \_\_\_\_\_
- 32. \_\_\_\_\_
- 33. \_\_\_\_\_
- 34. \_\_\_\_\_
- 35. \_\_\_\_\_
  
- 36. \_\_\_\_\_
- 37. \_\_\_\_\_
- 38. \_\_\_\_\_
- 39. \_\_\_\_\_
- 40. \_\_\_\_\_



## Formulas

$$\frac{\sin A}{a} = \frac{\sin B}{b} = \frac{\sin C}{c}$$

$$a^2 = b^2 + c^2 - 2bc \cos A$$

$$\cos A = \frac{b^2 + c^2 - a^2}{2cb}$$

$$\sigma = \sqrt{\frac{\sum(x - \bar{x})^2}{n}}$$

$$z = \frac{x - \mu}{\sigma}$$

$$x = \frac{-b \pm \sqrt{b^2 - 4ac}}{2a}$$

## z-score tables

z	0.00	0.01	0.02	0.03	0.04	0.05	0.06	0.07	0.08	0.09
0.0	0.5000	0.5040	0.5080	0.5120	0.5160	0.5199	0.5239	0.5279	0.5319	0.5359
0.1	0.5398	0.5438	0.5478	0.5517	0.5557	0.5596	0.5636	0.5675	0.5714	0.5753
0.2	0.5793	0.5832	0.5871	0.5910	0.5948	0.5987	0.6026	0.6064	0.6103	0.6141
0.3	0.6179	0.6217	0.6255	0.6293	0.6331	0.6368	0.6406	0.6443	0.6480	0.6517
0.4	0.6554	0.6591	0.6628	0.6664	0.6700	0.6736	0.6772	0.6808	0.6844	0.6879
0.5	0.6915	0.6950	0.6985	0.7019	0.7054	0.7088	0.7123	0.7157	0.7190	0.7224
0.6	0.7257	0.7291	0.7324	0.7357	0.7389	0.7422	0.7454	0.7486	0.7517	0.7549
0.7	0.7580	0.7611	0.7642	0.7673	0.7704	0.7734	0.7764	0.7794	0.7823	0.7852
0.8	0.7881	0.7910	0.7939	0.7967	0.7995	0.8023	0.8051	0.8078	0.8106	0.8133
0.9	0.8159	0.8186	0.8212	0.8238	0.8264	0.8289	0.8315	0.8340	0.8365	0.8389
1.0	0.8413	0.8438	0.8461	0.8485	0.8508	0.8531	0.8554	0.8577	0.8599	0.8621
1.1	0.8643	0.8665	0.8686	0.8708	0.8729	0.8749	0.8770	0.8790	0.8810	0.8830
1.2	0.8849	0.8869	0.8888	0.8907	0.8925	0.8944	0.8962	0.8980	0.8997	0.9015
1.3	0.9032	0.9049	0.9066	0.9082	0.9099	0.9115	0.9131	0.9147	0.9162	0.9177
1.4	0.9192	0.9207	0.9222	0.9236	0.9251	0.9265	0.9279	0.9292	0.9306	0.9319
1.5	0.9332	0.9345	0.9357	0.9370	0.9382	0.9394	0.9406	0.9418	0.9429	0.9441
1.6	0.9452	0.9463	0.9474	0.9484	0.9495	0.9505	0.9515	0.9525	0.9535	0.9545
1.7	0.9554	0.9564	0.9573	0.9582	0.9591	0.9599	0.9608	0.9616	0.9625	0.9633
1.8	0.9641	0.9649	0.9656	0.9664	0.9671	0.9678	0.9686	0.9693	0.9699	0.9706
1.9	0.9713	0.9719	0.9726	0.9732	0.9738	0.9744	0.9750	0.9756	0.9761	0.9767
2.0	0.9772	0.9778	0.9783	0.9788	0.9793	0.9798	0.9803	0.9808	0.9812	0.9817
2.1	0.9821	0.9826	0.9830	0.9834	0.9838	0.9842	0.9846	0.9850	0.9854	0.9857
2.2	0.9861	0.9864	0.9868	0.9871	0.9875	0.9878	0.9881	0.9884	0.9887	0.9890
2.3	0.9893	0.9896	0.9898	0.9901	0.9904	0.9906	0.9909	0.9911	0.9913	0.9916
2.4	0.9918	0.9920	0.9922	0.9925	0.9927	0.9929	0.9931	0.9932	0.9934	0.9936
2.5	0.9938	0.9940	0.9941	0.9943	0.9945	0.9946	0.9948	0.9949	0.9951	0.9952
2.6	0.9953	0.9955	0.9956	0.9957	0.9959	0.9960	0.9961	0.9962	0.9963	0.9964
2.7	0.9965	0.9966	0.9967	0.9968	0.9969	0.9970	0.9971	0.9972	0.9973	0.9974
2.8	0.9974	0.9975	0.9976	0.9977	0.9977	0.9978	0.9979	0.9979	0.9980	0.9981
2.9	0.9981	0.9982	0.9982	0.9983	0.9984	0.9984	0.9985	0.9985	0.9986	0.9986

z	0.09	0.08	0.07	0.06	0.05	0.04	0.03	0.02	0.01	0.00
-2.9	0.0014	0.0014	0.0015	0.0015	0.0016	0.0016	0.0017	0.0018	0.0018	0.0019
-2.8	0.0019	0.0020	0.0021	0.0021	0.0022	0.0023	0.0023	0.0024	0.0025	0.0026
-2.7	0.0026	0.0027	0.0028	0.0029	0.0030	0.0031	0.0032	0.0033	0.0034	0.0035
-2.6	0.0036	0.0037	0.0038	0.0039	0.0040	0.0041	0.0043	0.0044	0.0045	0.0047
-2.5	0.0048	0.0049	0.0051	0.0052	0.0054	0.0055	0.0057	0.0059	0.0060	0.0062
-2.4	0.0064	0.0066	0.0068	0.0069	0.0071	0.0073	0.0075	0.0078	0.0080	0.0082
-2.3	0.0084	0.0087	0.0089	0.0091	0.0094	0.0096	0.0099	0.0102	0.0104	0.0107
-2.2	0.0110	0.0113	0.0116	0.0119	0.0122	0.0125	0.0129	0.0132	0.0136	0.0139
-2.1	0.0143	0.0146	0.0150	0.0154	0.0158	0.0162	0.0166	0.0170	0.0174	0.0179
-2.0	0.0183	0.0188	0.0192	0.0197	0.0202	0.0207	0.0212	0.0217	0.0222	0.0228
-1.9	0.0233	0.0239	0.0244	0.0250	0.0256	0.0262	0.0268	0.0274	0.0281	0.0287
-1.8	0.0294	0.0301	0.0307	0.0314	0.0322	0.0329	0.0336	0.0344	0.0351	0.0359
-1.7	0.0367	0.0375	0.0384	0.0392	0.0401	0.0409	0.0418	0.0427	0.0436	0.0446
-1.6	0.0455	0.0465	0.0475	0.0485	0.0495	0.0505	0.0516	0.0526	0.0537	0.0548
-1.5	0.0559	0.0571	0.0582	0.0594	0.0606	0.0618	0.0630	0.0643	0.0655	0.0668
-1.4	0.0681	0.0694	0.0708	0.0721	0.0735	0.0749	0.0764	0.0778	0.0793	0.0808
-1.3	0.0823	0.0838	0.0853	0.0869	0.0885	0.0901	0.0918	0.0934	0.0951	0.0968
-1.2	0.0985	0.1003	0.1020	0.1038	0.1056	0.1075	0.1093	0.1112	0.1131	0.1151
-1.1	0.1170	0.1190	0.1210	0.1230	0.1251	0.1271	0.1292	0.1314	0.1335	0.1357
-1.0	0.1379	0.1401	0.1423	0.1446	0.1469	0.1492	0.1515	0.1539	0.1562	0.1587
-0.9	0.1611	0.1635	0.1660	0.1685	0.1711	0.1736	0.1762	0.1788	0.1814	0.1841
-0.8	0.1867	0.1894	0.1922	0.1949	0.1977	0.2005	0.2033	0.2061	0.2090	0.2119
-0.7	0.2148	0.2177	0.2206	0.2236	0.2266	0.2296	0.2327	0.2358	0.2389	0.2420
-0.6	0.2451	0.2483	0.2514	0.2546	0.2578	0.2611	0.2643	0.2676	0.2709	0.2743
-0.5	0.2776	0.2810	0.2843	0.2877	0.2912	0.2946	0.2981	0.3015	0.3050	0.3085
-0.4	0.3121	0.3156	0.3192	0.3228	0.3264	0.3300	0.3336	0.3372	0.3409	0.3446
-0.3	0.3483	0.3520	0.3557	0.3594	0.3632	0.3669	0.3707	0.3745	0.3783	0.3821
-0.2	0.3859	0.3897	0.3936	0.3974	0.4013	0.4052	0.4090	0.4129	0.4168	0.4207
-0.1	0.4247	0.4286	0.4325	0.4364	0.4404	0.4443	0.4483	0.4522	0.4562	0.4602
-0.0	0.4641	0.4681	0.4721	0.4761	0.4801	0.4840	0.4880	0.4920	0.4960	0.5000



STUDENT'S NAME \_\_\_\_\_

TEACHER'S NAME \_\_\_\_\_

***DO NOT OPEN THIS EXAMINATION PAPER UNTIL  
YOU ARE TOLD BY THE SUPERVISOR TO BEGIN***

FINAL EXAMINATION  
**MATHEMATICS 2201**

June 2013

Value: 80 Marks

Time: 3 hours

***General Instructions***

1. Students are required to do **ALL** items.
2. The examination consists of the following parts:  
**PART I:** Selected Response Value: 40 Marks  
**PART II:** Constructed Response Value: 40 Marks
3. Scientific and graphing calculators may be used.
4. Answers to **PART I** items are to be shaded on the computer scorable answer sheet. If a second sheet is provided for **PART I** items, letters should be clearly written and this sheet ***stapled to the front of*** the examination paper.
5. For **PART II** items, students are reminded to show all necessary steps and calculations as credit may be given for incomplete or for partially correct solutions. Correct answers without calculations will not merit full marks.

***Student Checklist***

***The following items are your responsibility. Please ensure that they are completed.***

- Check that you are doing the correct exam.
- Write your name on the top of this page and on any answer sheet.
- Check that the bubble sheet is adequately shaded.
- Check this exam to ensure that there are no missing pages.
- At the end of the examination period check that you have completed or at least attempted **ALL** items.

**Part I**  
**Total Value: 40 Marks**

1. What is the missing value in this table? (Level 1 - NL1 - Unit 1)

Time (hr)	1	2	3	4	5
Temperature (°C)	-3		-13	-18	-23

- A) -10  
B) -9  
C) -8  
D) -7
2. Which is a counterexample to the conjecture, "the difference of two numbers is always less than the smallest of the two numbers"? (Level 2 - NL1 - Unit 1)
- A)  $(-2) - (2)$   
B)  $(2) - (3)$   
C)  $(3) - (2)$   
D)  $(2) - (-2)$
3. Four people ran a race. Sue and Bob finished before Pat. Bob finished later than Sue. Bob and Pat finished before Tim. Who took third place? (Level 2 - NL1 - Unit 1)
- A) Bob  
B) Pat  
C) Sue  
D) Tim
4. What is the relationship between  $\angle w$  and  $\angle y$ ? (Level 1 - G1 - Unit 3)

- A) Alternate Interior Angles  
B) Corresponding Angles  
C) Same Side Interior Angles  
D) Vertically Opposite Angles

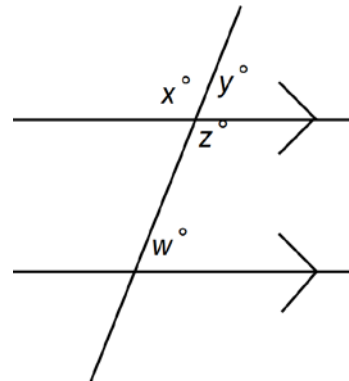

5. Which pair of triangles has the correct congruency relationship? (Level 2 – G1 – Unit3)

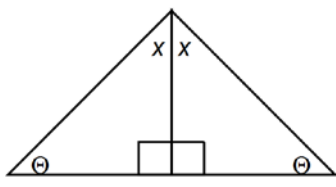
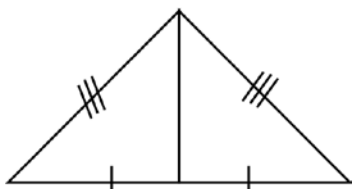
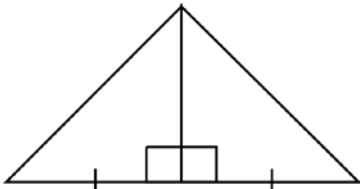
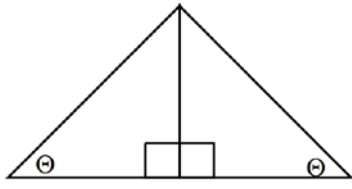
- A)   
AAA
- B)   
SSS
- C)   
ASA
- D)   
SAS

6. Which sets of lines ( $L_1$ ,  $L_2$ ) are parallel? (Level 2 – G2 – Unit 3)

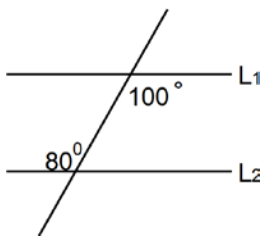
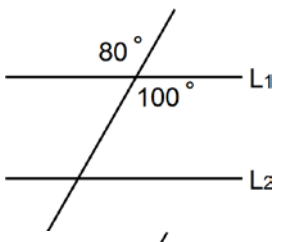
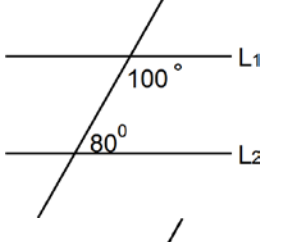
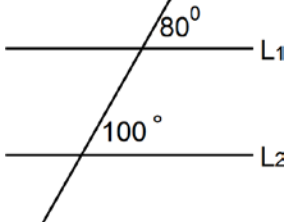
- A) 
- B) 
- C) 
- D) 

7. What is the sum of the measures of the interior angles of the polygon? (Level 2 – G1 – Unit 3)

- A)  $540^\circ$
- B)  $720^\circ$
- C)  $900^\circ$
- D)  $1080^\circ$



8. Identify the step which contains the error in the reason. (Level 2 – G1 – Unit 3)

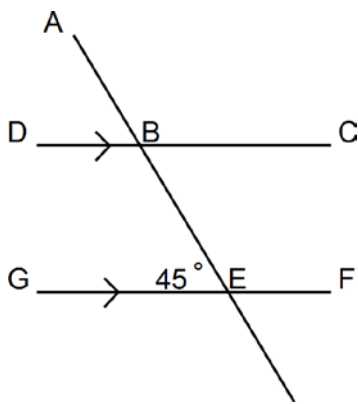

	Statement	Reason
Step 1	$\overline{DC} \parallel \overline{GF}$	Given
Step 2	$\angle BEG = 45^\circ$	Given
Step 3	$\angle BEG = \angle EBD$	Same side interior angles are equal
Step 4	$\angle EBD = 45^\circ$	Transitive property

- A) Step 1
- B) Step 2
- C) Step 3
- D) Step 4

9. Which is a proper application of the cosine law for  $\triangle PWQ$ ? (Level 1 – G3 – Unit 4)

- A)  $p^2 = q^2 + w^2 - 2qw \cos P$
- B)  $q^2 = p^2 + w^2 - 2qw \cos Q$
- C)  $\cos W = \frac{p^2 + w^2 - q^2}{2pw}$
- D)  $\cos Q = \frac{p^2 + w^2 - q^2}{2wq}$

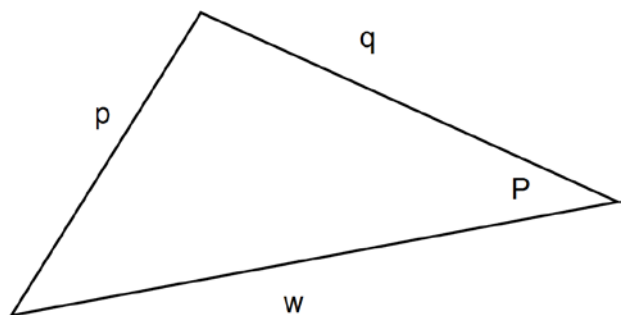



10. Which triangle can you use the law of sines to find  $x$  ? (Level 1 – G3 – Unit 4)

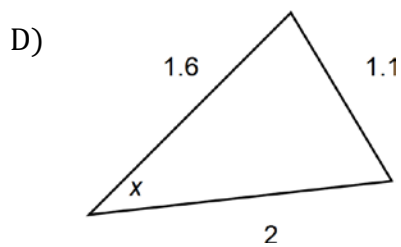
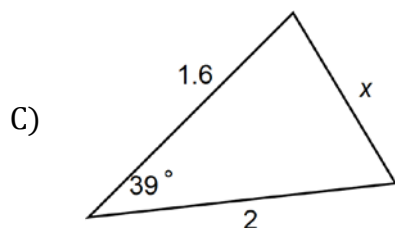
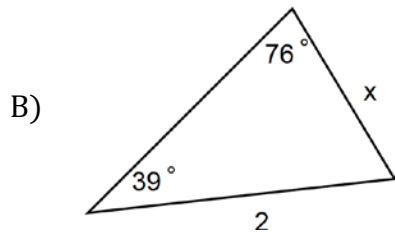
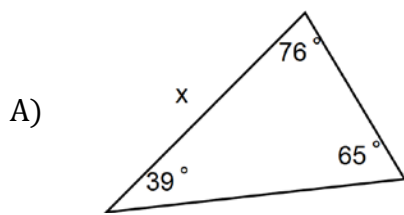

11. What is the measure of  $\angle A$ ? (Level 2 – G3 – Unit 4)

- A)  $37^\circ$
- B)  $42^\circ$
- C)  $51^\circ$
- D)  $67^\circ$

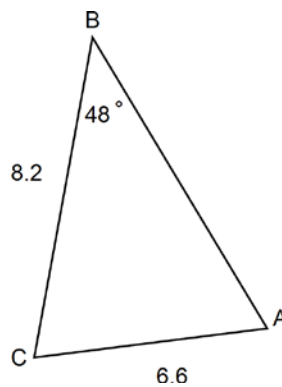

12. Find the length of  $\overline{RT}$ . (Level 2 – G3 – Unit 4)

- A) 1.6
- B) 2.5
- C) 4.7
- D) 7.4

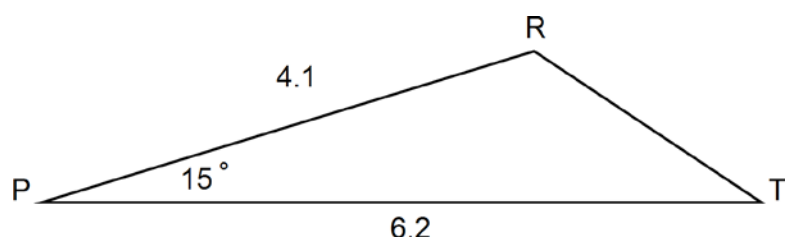

13. Which is expressed as an entire radical? (Level1 – NL3 – Unit 5)

- A)  $2^3\sqrt{8}$
- B)  $3\sqrt{4}$
- C)  $2\sqrt{5}$
- D)  $\sqrt{20}$

14. Which expression is equivalent to  $\sqrt{32}$ ? (Level 1 – NL3 – Unit 5)

- A)  $4\sqrt{2}$
- B)  $16\sqrt{2}$
- C)  $2\sqrt{4}$
- D)  $8\sqrt{4}$

15. Simplify:  $2\sqrt{3}(\sqrt{6} + 1)$  (Level 2 – NL3 – Unit 5)

- A)  $6\sqrt{2} + 1$
- B)  $6\sqrt{2} + 2\sqrt{3}$
- C)  $18\sqrt{2} + 1$
- D)  $18\sqrt{2} + 2\sqrt{3}$

16. Simplify:  $\frac{\sqrt{5x}}{\sqrt{2}}$  (Level 2 – NL3 – Unit 5)

- A)  $\frac{\sqrt{5x}}{2}$
- B)  $\frac{\sqrt{10x}}{2}$
- C)  $\frac{\sqrt{10x}}{4}$
- D)  $\frac{5\sqrt{x}}{2}$

17. State the restrictions on  $x$  for the radical equation:  $\sqrt{x - 4} = 2$  (Level 2 – NL4 – Unit 5)

- A)  $x \geq -4, x \in R$
- B)  $x \leq -4, x \in R$
- C)  $x \geq 4, x \in R$
- D)  $x \leq 4, x \in R$

18. Simplify:  $\frac{\sqrt{80x^5}}{\sqrt{5x}}$  (Level 2 – NL3- Unit 5)

- A)  $\sqrt{75x^4}$
- B)  $\sqrt{16x^5}$
- C)  $4x^2$
- D)  $16x^4$

19. Simplify:  $\sqrt{12} - \sqrt{18} - \sqrt{27} + \sqrt{8}$  (Level 2 – NL3 – Unit 5)

- A)  $-\sqrt{25}$
- B)  $-\sqrt{5}$
- C)  $-\sqrt{3} - \sqrt{2}$
- D)  $-\sqrt{3} - 5\sqrt{2}$

20. A study of income in a large city states the mean family income is \$29 500. The study states the results are accurate 9 times out of 10. What is the confidence level in this situation? (Level 1 – S2 – Unit 6)

- A) 90%
- B) 95%
- C) 99%
- D) 100%

21. How many scores are greater than or equal to 50? (Level 2 – S1 – Unit 6)

- A) 12
- B) 24
- C) 29
- D) 32

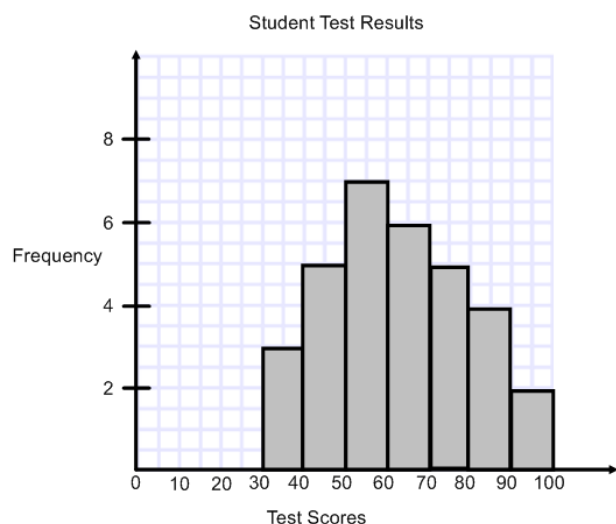

22. Which graph represents data which approximates the normal distribution? (Level 1

- S1 - Unit 6)

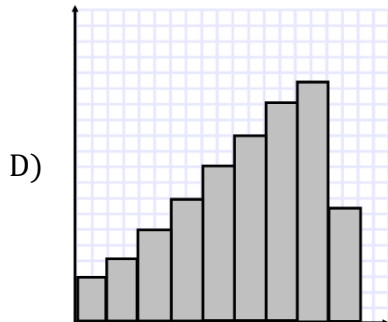
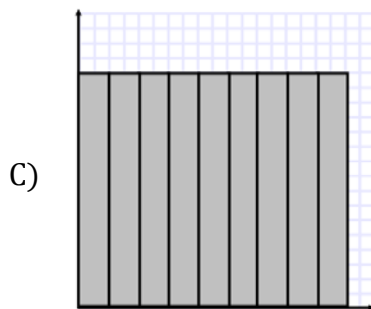
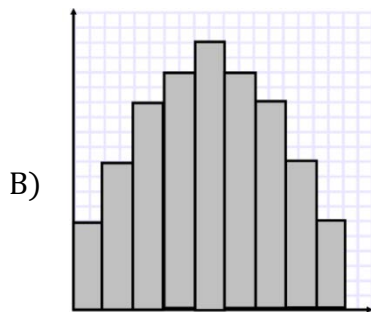
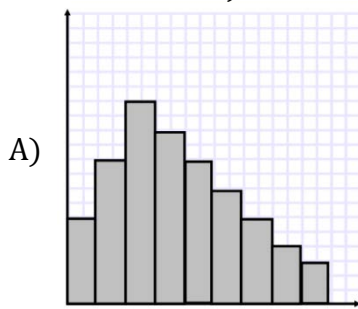

23. The number of goals by all hockey players in the NHL is normally distributed. The mean number of goals is 18 with a standard deviation of 4 goals. In what goal range would 68% of the players score? (Level 2 - S1 - Unit 6)

A) 10 to 22

B) 10 to 26

C) 14 to 22

D) 14 to 26

24. A random survey of 100 teens reported that 28% of those surveyed exercise at least three times per week. The results are considered accurate within  $\pm 4$  percent, 19 times out of 20. If the sample size is increased, which statement is most accurate? (Level 1 - S2-Unit 6)

- A) The margin of error will decrease
- B) The margin of error will increase
- C) The mean will decrease
- D) The mean will increase

25. What is the y-intercept of  $y = 3x^2 + 4x + 5$ ? (Level 1 - RF1 - Unit 7)

- A) 2
- B) 3
- C) 4
- D) 5

26. A parabola passes through the points (4, 9) and (-8, 9). What is the equation of the axis of symmetry? (Level 2 - RF1 - Unit 6)

- A)  $x = -6$
- B)  $x = -3$
- C)  $x = -2$
- D)  $x = -1$

27. What is the vertex of the graph? (Level 1 - RF 1 - Unit 7)

- A) (-3, 2)
- B) (-2, 3)
- C) (2, -3)
- D) (3, -2)

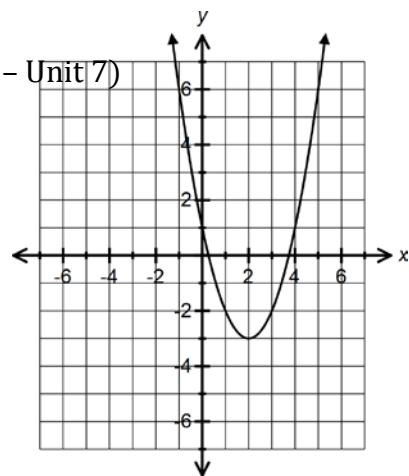

28. What is the range of  $y = -(x + 4)^2 + 9$ ? (Level 2 - RF1 - Unit 7)

- A)  $\{y|y \geq 9, y \in R\}$
- B)  $\{y|y \leq 9, y \in R\}$
- C)  $\{y|y \geq -4, y \in R\}$
- D)  $\{y|y \leq -4, y \in R\}$

29. What is the vertex of  $y = 2x^2 - 12x + 14$ ? (Level 2 - RF1 - Unit 7)

- A)  $(-3, 38)$
- B)  $(-3, 68)$
- C)  $(3, -10)$
- D)  $(3, -4)$

30. Change  $y = (x + 2)(x - 5)$  to the form  $y = ax^2 + bx + c$ . (Level 2 - RF1- Unit 7)

- A)  $y = x^2 - 7x - 10$
- B)  $y = x^2 - 7x - 3$
- C)  $y = x^2 - 3x - 10$
- D)  $y = x^2 - 3x - 3$

31. For the graph, what are the roots of the quadratic function? (Level 1 - RF2 - Unit 8)

- A)  $x = -3, x = -\frac{1}{2}$
- B)  $x = -3, x = \frac{1}{2}$
- C)  $x = 3, x = -\frac{1}{2}$
- D)  $x = 3, x = \frac{1}{2}$

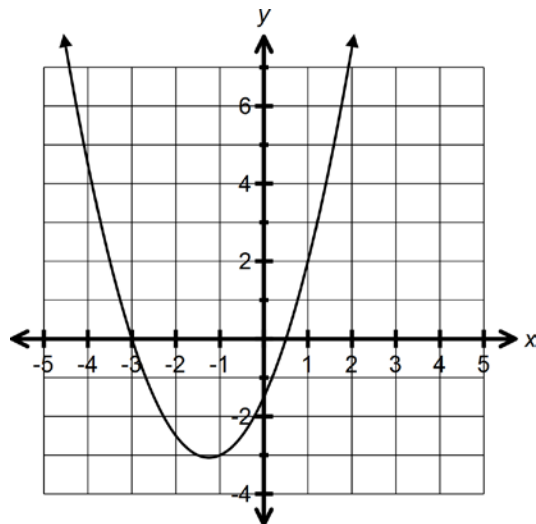

32. Solve:  $(x - 100)(x + 58) = 0$  (Level 1- RF2 - Unit 8)

- A)  $x = -100, x = -58$
- B)  $x = -100, x = 58$
- C)  $x = 100, x = -58$
- D)  $x = 100, x = 58$

33. Solve:  $2x^2 - 10 = 0$  (Level 2 -RF2 - Unit 8)

- A)  $x = \pm 10$
- B)  $x = \pm 5$
- C)  $x = \pm\sqrt{5}$
- D)  $x = \pm\sqrt{10}$

34. Solve:  $3x^2 - 2x - 5 = 0$  (Level 2 - RF2 - Unit 8)

A)  $x = -\frac{5}{3}, x = -1$

B)  $x = -\frac{5}{3}, x = 1$

C)  $x = \frac{5}{3}, x = -1$

D)  $x = \frac{5}{3}, x = 1$

35. Simplify:  $x = \frac{8 \pm \sqrt{128}}{2}$  (Level 2 - RF2 - Unit 8)

A)  $x = -4, x = 12$

B)  $x = 0, x = 16$

C)  $x = 4 \pm 4\sqrt{2}$

D)  $x = 4 \pm 8\sqrt{2}$

36. Which equation has roots  $x = -10$  and  $x = 6$  (Level 1 - RF3 - Unit 8)

A)  $y = a(x - 10)(x + 6)$

B)  $y = a(x - 10)(x - 6)$

C)  $y = a(x + 10)(x - 6)$

D)  $y = a(x + 10)(x + 6)$

37. 240 000 L of water is consumed among 60 households in the neighborhood. What is the rate per household in litres? (Level 1 - M1 - Unit 9)

A) 0.000 25

B) 4 000

C) 40 000

D) 14 400 000

38. A map measuring 20 cm by 25 cm has its dimensions enlarged using a scale of 1 cm : 2 cm. By what factor does the area increase? (Level 2 – M2 – Unit 9)

- A)  $\frac{1}{4}$
- B)  $\frac{1}{2}$
- C) 2
- D) 4

39. Six bottles of cola costs \$2.99. A convenience store manager plans to purchase 140 bottles in order to fill the store cooler. If she can only purchase the bottles by packages of six, how much does she spend? (Level 2 – M2 – Unit 9)

- A) \$46.82
- B) \$68.77
- C) \$69.77
- D) \$71.76

40. Andrew sent 4 650 text messages in 31 days. Sean sent 1 155 in 7 days. Who will have the highest text rate per day and by how many? (Level 2 – M1 – Unit 9)

- A) Andrew (extra 15 texts per day)
- B) Andrew (extra 30 texts per day)
- C) Sean (extra 15 texts per day)
- D) Sean (extra 30 texts per day)



SECTION II

Total Value: 40 Marks

Answer ALL items in the space provided. Show ALL workings.

Value

- 3 41. Prove deductively the sum of six consecutive positive numbers is a multiple of three. (Level 2 – NL1 – Unit 1)

- 3 42. Given:  $\overline{AC} = \overline{EC}$   
 $\overline{BC} = \overline{DC}$

Prove:  $\triangle ABC \cong \triangle EDC$

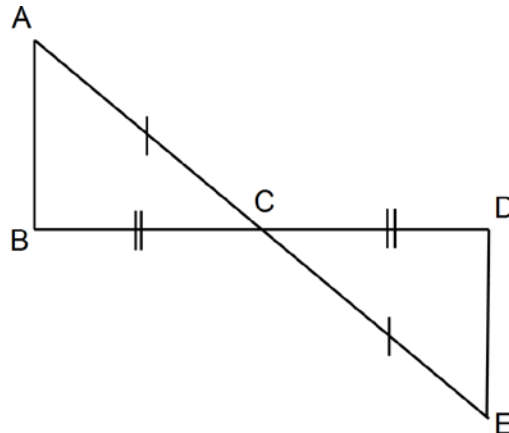

Statements	Reason

- 2 43. Determine the value of  $x$ .

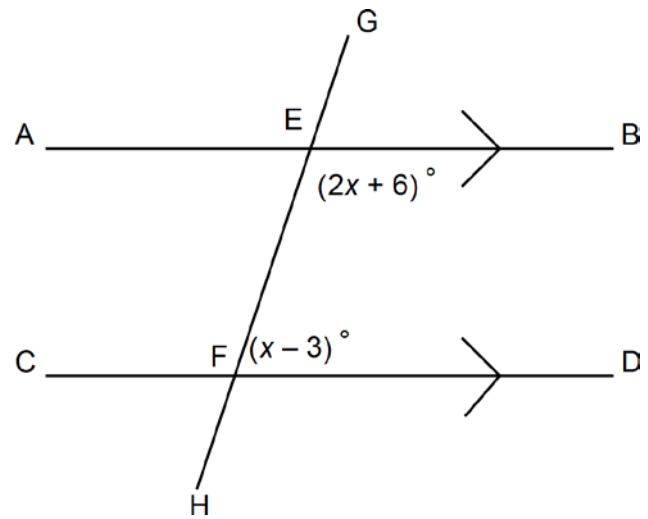

- 2 44. A) A telephone pole is supported by two wires on opposite sides. At the top of the pole, the wires meet to form an angle of  $50^\circ$ . On the ground, the ends of the wires are 20 ft apart. Wire B make a  $45^\circ$  angle with the ground. What is the length of wire A?(Level 3 - G3 - Unit 4)

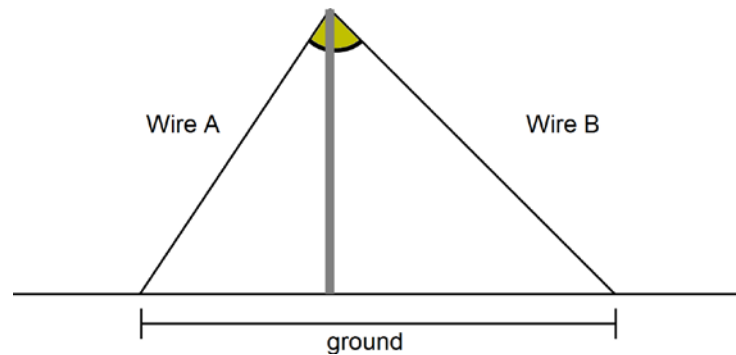

- 2 B) Find the values of angle  $\theta$  to the nearest degree.

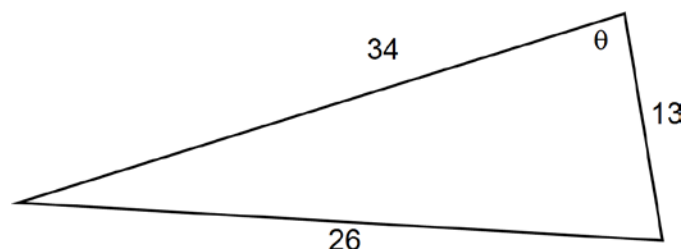

2      45.      Solve:  $\sqrt{2x - 1} = 5$  (Level 2 - NL4 - Unit 5)

2      46.      Simplify:       $(\sqrt{3} + \sqrt{2})^2$  (Level 2 - NL3 - Unit 5)

3      47.      A dog kennel has an area of  $15\sqrt{2} \text{ m}^2$ , and a width of  $\sqrt{6} \text{ m}$ . Determine the perimeter of the dog kennel in simplest form, using exact values. (Level 3 - NL3 - Unit 5)

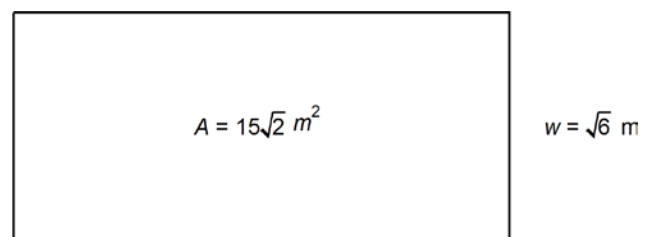

48. The mean life of Brand A batteries is 160 hours with a standard deviation of 20 hours. (Level 2 – S1 – Unit 6)
- 2 A) Determine the z-score of a battery that lasted 170 hours.
- 1 B) Using z-scores, what percent of the batteries will last less than 170 hours?
49. The results of a math unit test are normally distributed with a mean score of 76 and a standard deviation of 7. (Level 1 and 2 – S1 – Unit 6)
- 1 A) Draw and label the normal curve to represent this data.
- 1 B) What percent of the student scored between 62 and 83?

- 3 50. Bob kicked a beach ball into the air. After 3 seconds, the ball reached a maximum height of 5 m. If the ball was in the air for 6 seconds before it landed, determine the quadratic function that describes the path of the beach ball. (Level 3 – RF2 – Unit 7)

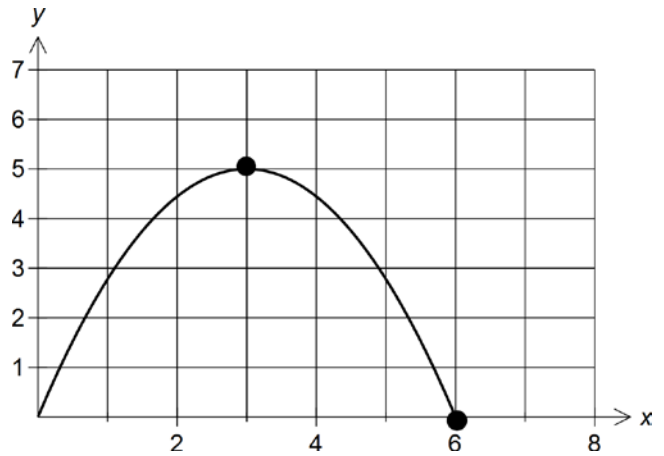

- 3 51. What is the vertex of  $y = 3(x - 2)(x + 10)$ ? (Level 2 – RF1 – Unit 7)

- 3 52. The sum of the squares of two positive consecutive integers is 113. What are the two integers? (Level 3 – RF2 – Unit 8)

3      53.      Find the zeros of  $y = 9x^2 - 6x - 1$ . (Level 2 - RF2 - Unit 8)

2      54.      The floor plan has a scale of 1 unit = 12 inches. The owner intends to use 6 inch by 6 inch square tiles to cover the floor of the bathroom. Tiles cost \$0.99 each. What is the total cost of the tiles?      (Level 2 - M1 - Unit 9)

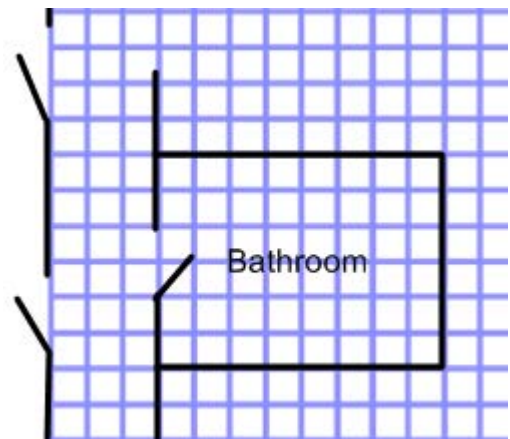

- 2 55. An underground storage tank is used to collect storm water.

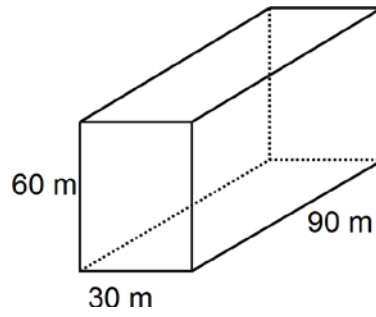

A new tank is needed with a volume of 8 times the present tank. Determine the dimensions of the new tank if every side is enlarged by the same factor.  
(Level 2 – M2- Unit 9)