

**DO NOT OPEN THIS EXAMINATION PAPER UNTIL YOU ARE TOLD BY
THE SUPERVISOR TO BEGIN**

Labrador School Board

Mathematics 1201

Final Examination

June 12th, 2012

Student Name: _____

Teacher Name: _____

Total Value: 100 marks

Time: 3 Hours

GENERAL INSTRUCTIONS

1. Candidates are required to do all items.
2. The examination has a total of 23 pages consisting of the following parts:

Part I: 40 Multiple Choice Items	Value: 40 Marks
Part II: 17 Constructed Response Questions	Value: 60 Marks
3. **Page 23 is a formulae sheet** to be used for the exam. This page may be removed.
4. Part I should be completed on the bubble sheets provided.
5. Answers to the constructed response questions for Part II are to be placed in the spaces provided.
6. For Part II items, candidates are reminded to show ALL necessary steps and calculations. Partial credit may be awarded for logical work even though you might not arrive at the correct solution. Correct answers without appropriate calculations will not merit full marks.
7. A self powered calculator may be used for calculations and to obtain special values. Graphing calculators are to be reset before the examination begins.

REGULATIONS FOR CANDIDATES

Candidates are expected to be thoroughly familiar with all regulations pertaining to their conduct during examinations. Candidates must comply with all requirements governing the following matters.

- | | |
|---|---|
| <ul style="list-style-type: none">• Materials required• Leaving the room• Materials not permitted• Models of calculators permitted | <ul style="list-style-type: none">• Use of pen or pencil• Use of unauthorized means and penalties• Completion of required information• Communication during the exam |
|---|---|

PART I
Total Value: 40 Marks

1. Which is the best referent for 1 yard?
A) height of a door knob from the floor
B) length of the ice surface in a hockey arena
C) length of a screwdriver
D) width of your thumb
2. A student ran 60 feet. How many yards did the student run?
A) 5
B) 20
C) 180
D) 720
3. What is the surface area of the regular tetrahedron to the nearest square centimetre if $AB = 5.0$ cm and $CD = 5.8$ cm?

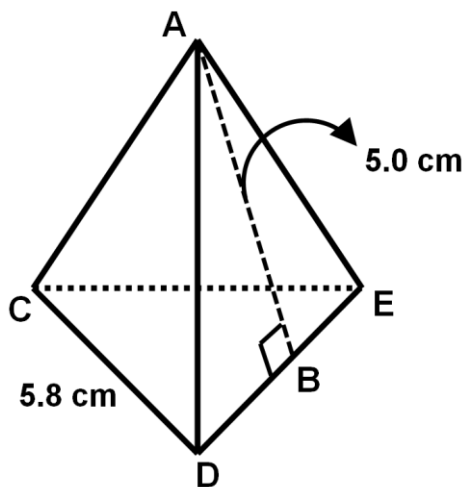

4. Betty has 18 yd. of material that she will cut into strips that must be exactly 15 in. wide. How many strips can Betty make?
A) 3
B) 6
C) 43
D) 44

5. The volume of a right cone is 14.7 cm^3 . If diameter $AB = 3.7 \text{ cm}$, what is the height, h , of the cone to the nearest tenth of a centimetre?

- A) 0.3
 B) 1.0
 C) 1.4
 D) 4.1

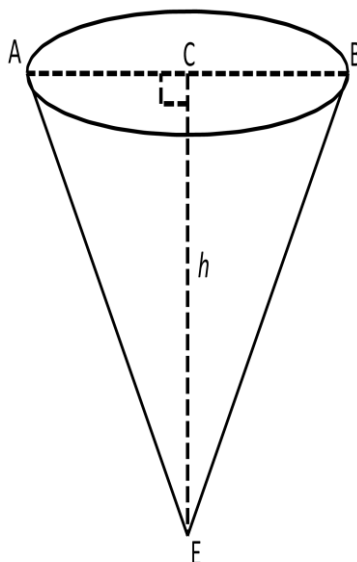

6. A sphere has a surface area of 6.4 m^2 . What is the diameter of the sphere to the nearest tenth of a metre?

- A) 0.5
 B) 0.7
 C) 1.0
 D) 1.4

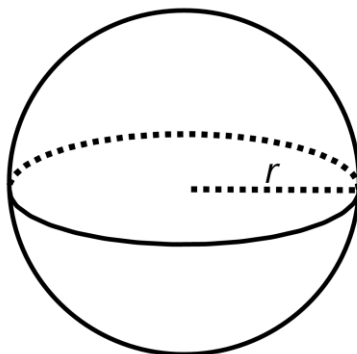

7. Which ratio represents $\cos \angle A$?

- A) $\frac{5}{13}$
 B) $\frac{5}{12}$
 C) $\frac{12}{13}$
 D) $\frac{13}{5}$

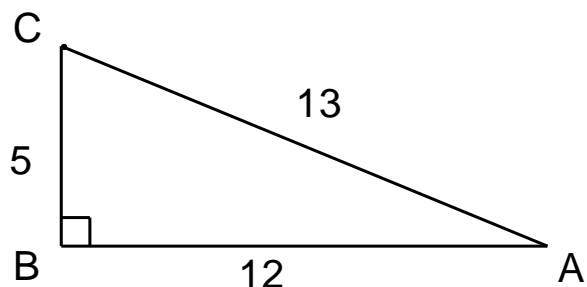

8. What is the measure of $\angle A$ to the nearest tenth of a degree?

- A) 24.2
 B) 26.7
 C) 63.3
 D) 65.8

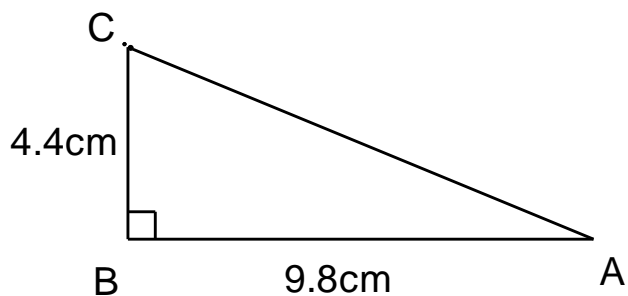

9. A guy wire is attached to a tower at a point that is 6.4 m above the ground. The angle of inclination of the wire is 62° . What is the length of the wire to the nearest tenth of a metre?

- A) 3.4
 B) 5.7
 C) 7.2
 D) 13.6

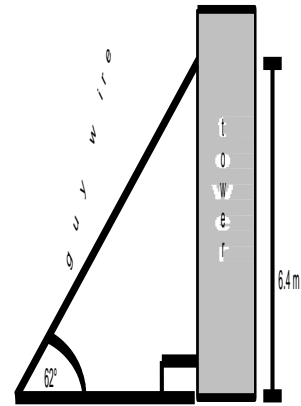

10. Sarah is standing 52 inches from the base of a tree. Using a clinometer, she determines the angle of inclination from her eye level to the top of the tree to be 32° . If her eyes are 60 inches above the ground, what is the height of the tree to the nearest tenth of an inch?

- A) 32.5
 B) 83.2
 C) 92.5
 D) 143.2

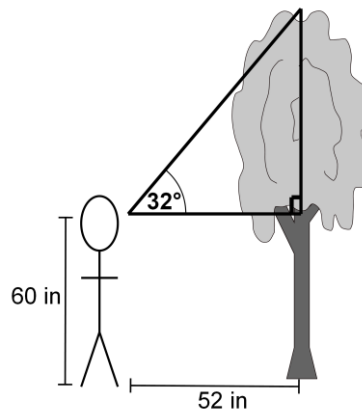

11. What is the greatest common factor of 54, 150 and 180?

- A) 6
 B) 9
 C) 30
 D) 54

12. Evaluate: $\sqrt[3]{-64} + \sqrt{\frac{1}{4}}$

- A) $-3\frac{15}{16}$
 B) $-3\frac{1}{2}$
 C) $4\frac{1}{16}$
 D) $4\frac{1}{2}$

13. Which is irrational?

A) $\sqrt[3]{-8}$

B) $-\sqrt{\frac{4}{9}}$

C) $\sqrt{2.25}$

D) $\sqrt{14}$

14. Simplify: $\frac{x^6 y^9 z^2}{xy^4 z^6}$

A) $x^5 y^5 z^4$

B) $x^6 y^5 z^4$

C) $\frac{x^5 y^5}{z^4}$

D) $\frac{x^6 y^5}{z^4}$

15. What is $\sqrt[4]{8^3}$ expressed as a power?

A) $8^{\frac{-4}{3}}$

B) $8^{\frac{-3}{4}}$

C) $8^{\frac{3}{4}}$

D) $8^{\frac{4}{3}}$

16. Evaluate: $\left(-\frac{8}{27}\right)^{-\frac{2}{3}}$

A) $-\frac{9}{4}$

B) $-\frac{4}{9}$

C) $\frac{4}{9}$

D) $\frac{9}{4}$

17. Simplify: $(x^{-2}y^4)^{-3}$

A) $\frac{x^5}{y}$

B) $\frac{y}{x^5}$

C) $\frac{x^6}{y^{12}}$

D) $\frac{y^{12}}{x^6}$

18. Simplify: $\frac{\left(a^2 b^{\frac{1}{2}}\right)\left(a^{\frac{1}{3}} b^3\right)}{\left(ab^2\right)}$

A) $\frac{a^{\frac{2}{3}}}{b^3}$

B) $a^{\frac{8}{3}} b^{\frac{9}{2}}$

C) $a^7 b^5$

D) $a^{\frac{4}{3}} b^{\frac{1}{2}}$

19. Which multiplication does the set of algebra tiles represent? (Note: shaded tiles represent positives.)

A) $(2x+2)(2x+2)$

B) $(2x^2+2)(2x^2-2)$

C) $(2x^2+2x)(2x^2+2x)$

D) $(2x+2)(2x-2)$

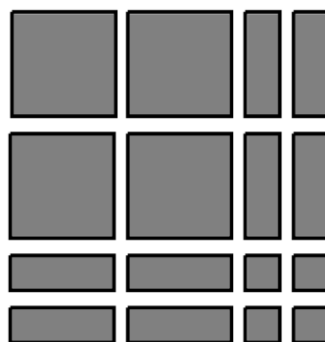

20. Factor completely: $44x+99x^2$

A) $x(44+99x)$

B) $11(4x+9x^2)$

C) $11x(4+9x)$

D) $22x(2+9x)$

21. Factor: $x^2 + 9x - 36$

- A) $(x+12)(x-3)$
- B) $(x-12)(x+3)$
- C) $(x-2)(x+18)$
- D) $(x-18)(x+2)$

22. Expand and simplify: $(6p+3)(5p-6)$

- A) $30p^2 + 21p - 18$
- B) $30p^2 - 21p - 18$
- C) $30p^2 + 51p - 18$
- D) $30p^2 - 51p - 18$

23. Factor: $16x^2 - 81y^2$

- A) $(4x-9y)^2$
- B) $(4x+9y)^2$
- C) $(16x+9y)(x-9y)$
- D) $(4x+9y)(4x-9y)$

24. Factor: $4a^2 + 12a + 9$

- A) $(2a-3)(2a+3)$
- B) $(2a+3)(2a+3)$
- C) $(4a-1)(a+9)$
- D) $(4a+1)(a+9)$

25. Which polynomial represents the area of the rectangle?

- A) $8x^2 + 36xy - 20y^2$
- B) $8x^2 + 22xy - 20y^2$
- C) $16x^2 + 72xy - 40y^2$
- D) $8x^2 - 36xy - 20y^2$

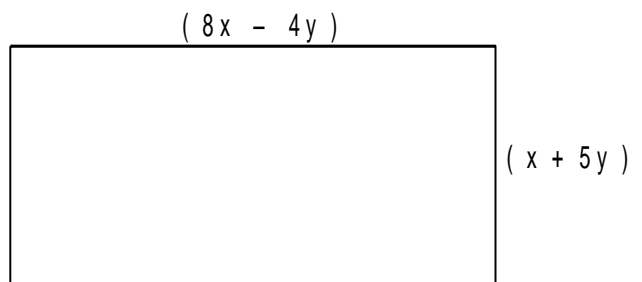

26. Factor completely: $8y^2 - 28y + 12$

- A) $2(4y-2)(y-3)$
- B) $2(4y-3)(y-2)$
- C) $4(2y-1)(y-3)$
- D) $4(2y-3)(y-1)$

27. Which set of ordered pairs represents a function?

- A) $\{(2, 5), (3, 8), (4, 11), (2, -1)\}$
- B) $\{(4, 6), (5, -7), (7, 9), (8, -10)\}$
- C) $\{(-3, -8), (-1, -6), (-2, 5), (-2, 7)\}$
- D) $\{(2, 0), (4, -1), (4, 5), (-8, 0)\}$

28. What is the domain of the graphed relation?

- A) $[-5, 3]$
- B) $[-5, 3)$
- C) $(-5, 3]$
- D) $(-5, 3)$

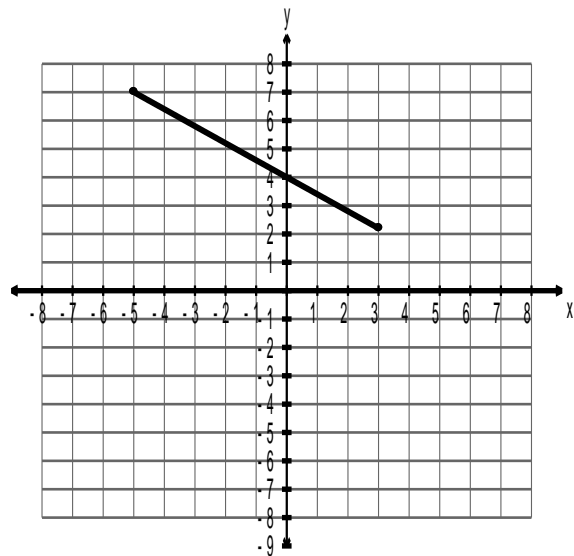

29. The function $C(f) = \frac{5}{9}(f-32)$ converts a temperature, f degrees Fahrenheit, to C degrees Celsius. What is the temperature in degrees Fahrenheit if $C(f) = 30^\circ$?

- A) 34
- B) 49
- C) 86
- D) 112

30. For a service call, an electrician charges an initial fee of \$65, plus \$45 for every 30 minutes worked. What is the rate of change, in dollars per hour, of this linear relation?

- A) 45
- B) 90
- C) 110
- D) 155

31. Which relation does **NOT** represent a function?

A)

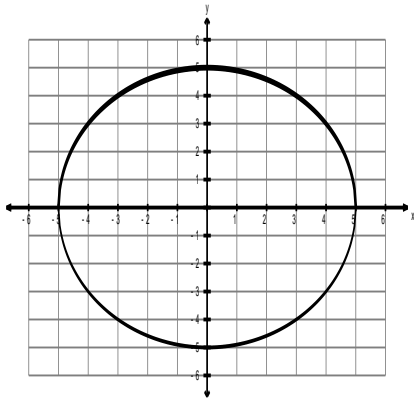

B)

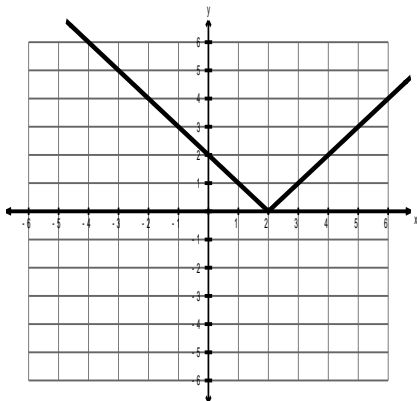

C)

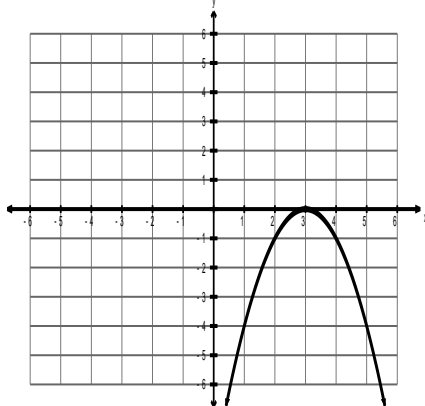

D)

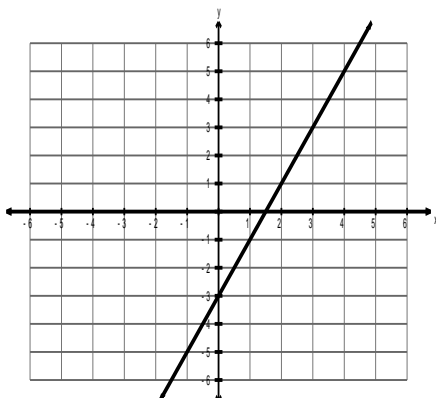

32. What is the equation of the line?

- A) $2x + 3y + 12 = 0$
- B) $2x + 3y - 12 = 0$
- C) $2x - 3y + 12 = 0$
- D) $2x - 3y - 12 = 0$

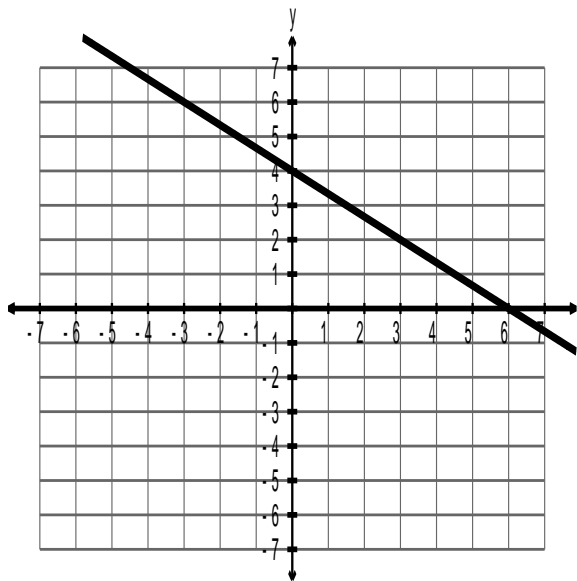

33. What is the slope of a line perpendicular to the given line?

- A) $-\frac{5}{3}$
- B) $-\frac{3}{5}$
- C) $\frac{3}{5}$
- D) $\frac{5}{3}$

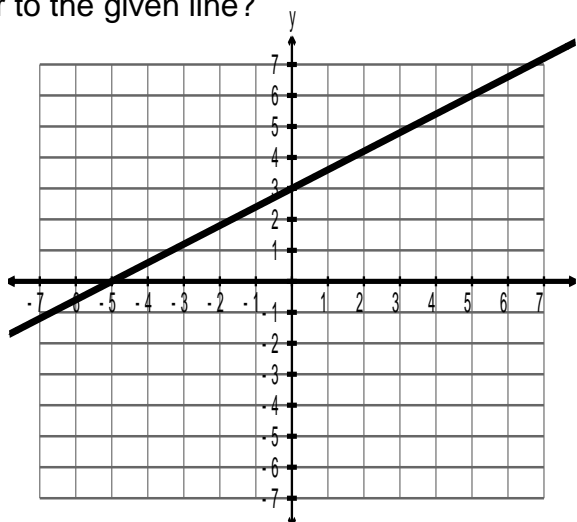

34. A line has slope $\frac{1}{2}$ and passes through the point $(3, -4)$. What is its equation in slope-point form?

- A) $y - 4 = \frac{1}{2}(x - 3)$
- B) $y - 4 = \frac{1}{2}(x + 3)$
- C) $y + 4 = \frac{1}{2}(x - 3)$
- D) $y + 4 = \frac{1}{2}(x + 3)$

35. What is the slope-intercept form of $-3x + 6y + 30 = 0$?

- A) $y = -\frac{1}{2}x - 5$
- B) $y = -\frac{1}{2}x + 5$
- C) $y = \frac{1}{2}x - 5$
- D) $y = \frac{1}{2}x + 5$

36. Which represents $y = -3$?

A)

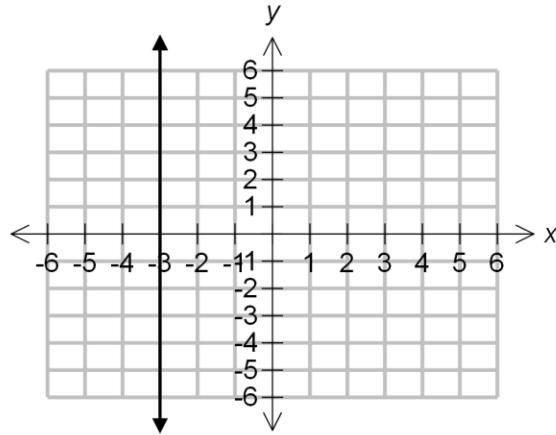

B)

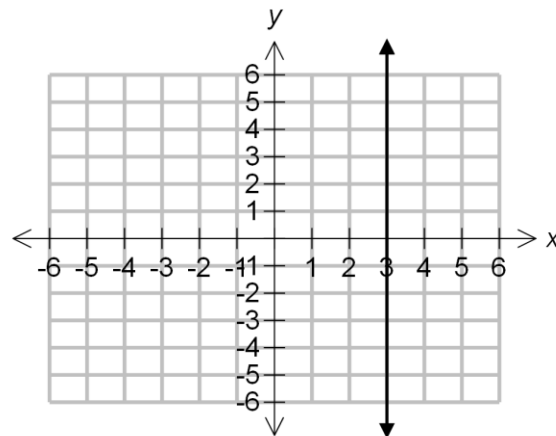

C)

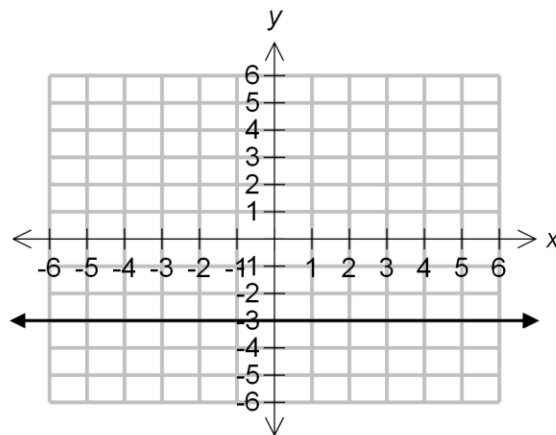

D)

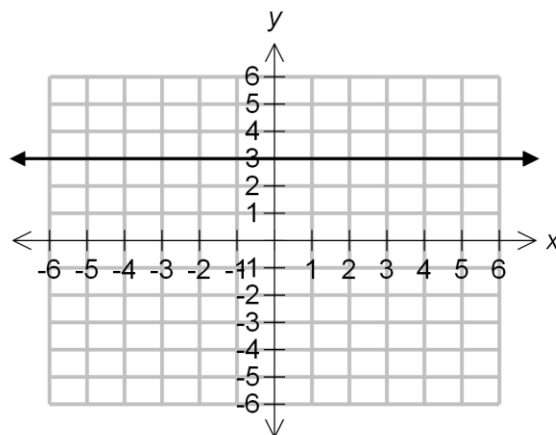

37. Don operates a snow clearing business. He charges \$22 for a small driveway (S) and \$30 for a large driveway (L). One weekend Don made \$326 by clearing 13 driveways. Which linear system models this situation?

A) $\begin{cases} S + L = 13 \\ 22S + 30L = 326 \end{cases}$

B) $\begin{cases} S + L = 13 \\ 30S + 22L = 326 \end{cases}$

C) $\begin{cases} S + L = 326 \\ 22S + 30L = 13 \end{cases}$

D) $\begin{cases} S + L = 326 \\ 30S + 22L = 13 \end{cases}$

38. Solve: $\begin{cases} 2x - y = 4 \\ x + y = 2 \end{cases}$

A) $(-1, 3)$

B) $(0, 2)$

C) $(2, 0)$

D) $(3, -1)$

39. How many solutions does the graphed linear system contain?

A) infinite

B) none

C) one

D) two

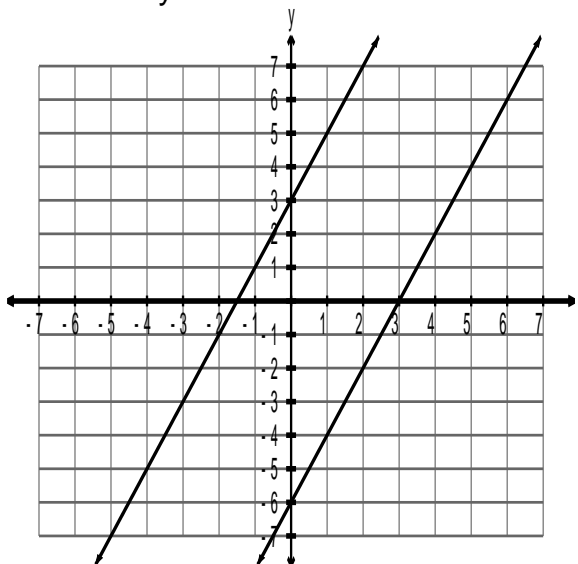

40. Which graph represents the solution to the linear system $\begin{cases} y = -3x - 5 \\ y = 3x + 1 \end{cases}$?

A)

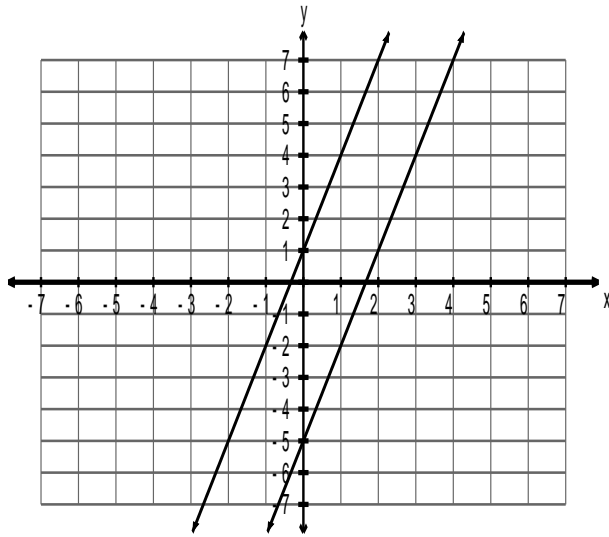

B)

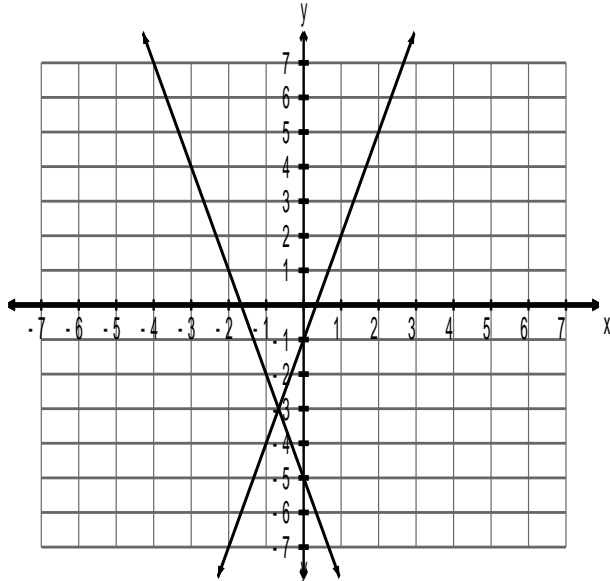

C)

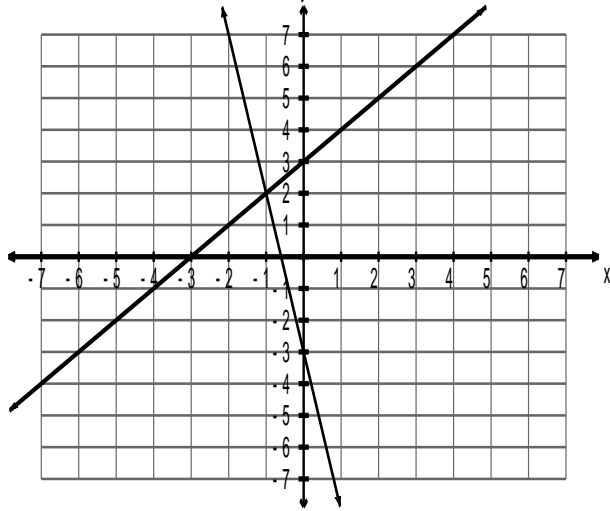

D)

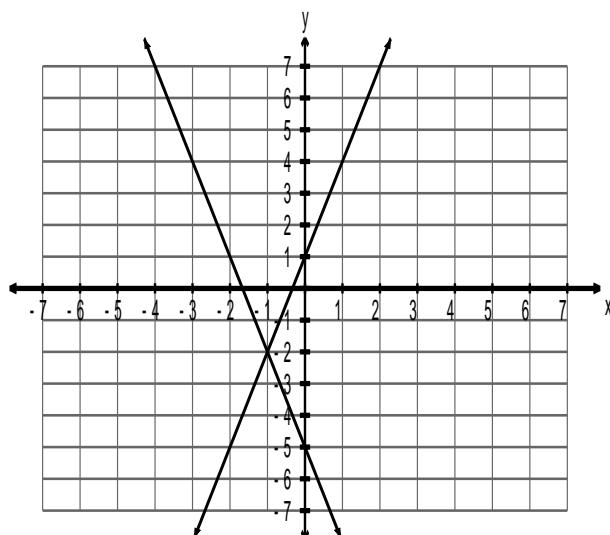

PART II

Total Value: 60 marks

Value

- 4 41. The right square pyramid is such that $BC=40$ cm and $AF=25$ cm. Find the volume of the right square pyramid to the nearest cubic centimeter.

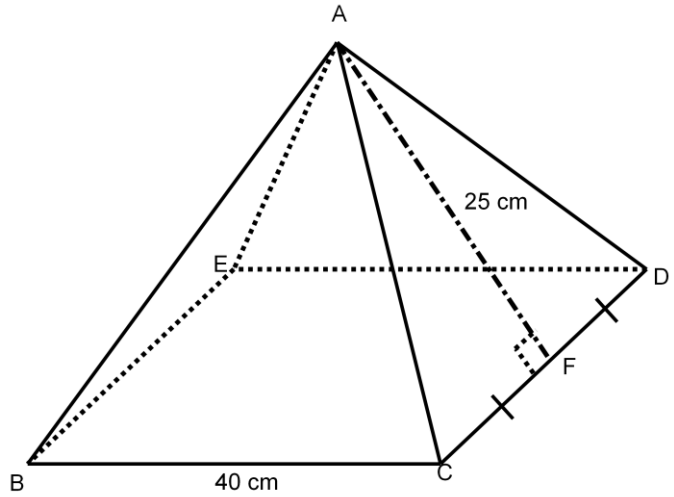

- 4 42. A farmer wishes to paint the exterior of his grain storage facility with dimensions as shown. If a can of paint covers 460 ft^2 , how many cans of paint will the farmer need to purchase? (Note: the bottom of the storage facility is **NOT** to be painted.)

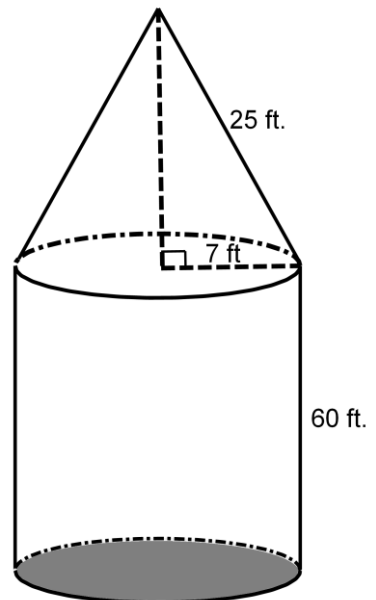

- 4 43. Solve $\triangle PQR$. Give the measures to the nearest tenth.

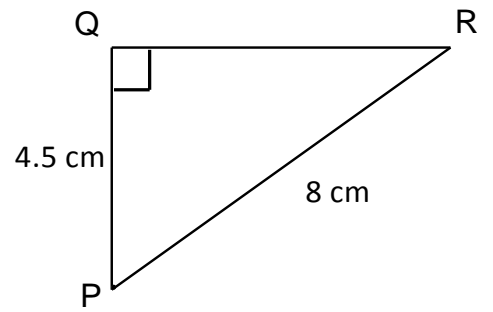

- 4 44. A lighthouse keeper spots two sailboats in distress. Sailboat A is observed at an angle of depression of 21° and sailboat B at an angle of depression of 8° . If the lighthouse keeper is 12.5 m above the ground, what is the distance x between the two sailboats?

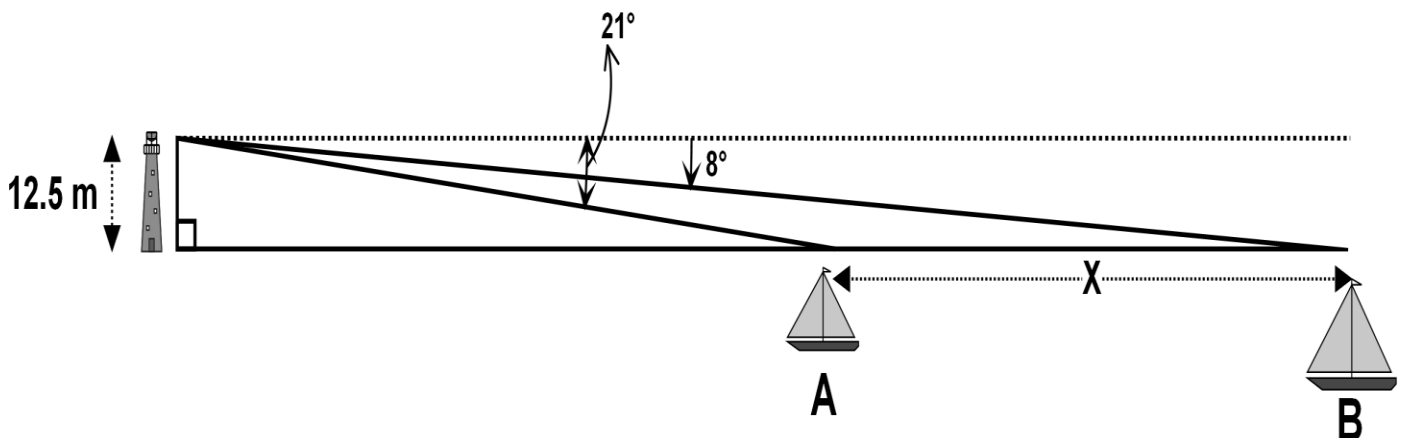

- 3 45. Shannon's rectangular dining room is 12 ft by 15 ft. There is a square rug that covers one-fourth the area of the floor. Determine the side length of the square rug. Express your answer in mixed radical form.

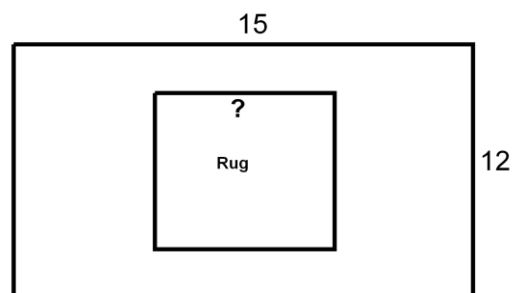

- 3 46. a) The volume of a sphere is 248.5 cm^3 . What is the radius?

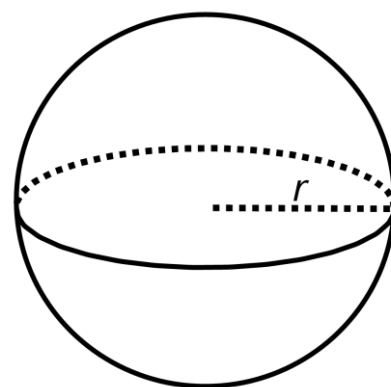

- 1 b) What is the surface area of the sphere?

- 3 47. Stephen completed a math problem and made a mistake. In which step does his error occur? Rewrite Stephen's solution so that it is correct.

$$\frac{\left(x^{\frac{1}{2}} y^{-\frac{1}{4}}\right)^4 \left(x^0 y^{-\frac{2}{3}}\right)^{-3}}{\left(x^{\frac{3}{2}} y\right)}$$

$$\text{Step 1} = \frac{\left(x^{\frac{4}{2}} y^{-\frac{4}{4}}\right) \left(x^0 y^{\frac{6}{3}}\right)}{\left(x^{\frac{3}{2}} y\right)}$$

$$\text{Step 2} = \frac{\left(x^2 y^{-1}\right) \left(y^2\right)}{\left(x^{\frac{3}{2}} y\right)}$$

$$\text{Step 3} = \frac{\left(x^2 y^{-2}\right)}{\left(x^{\frac{3}{2}} y\right)}$$

$$\text{Step 4} = x^{\frac{1}{2}} y^{-3}$$

$$\text{Step 5} = \frac{x^{\frac{1}{2}}}{y^3}$$

- 3 48. Expand and simplify: $(2x^2 + 5x - 6)(5x^2 - 2x + 3)$

3 49. Factor completely: $6x^3 - 2x^2 - 8x$

3 50. Use an area model (*i.e.* algebra tiles, rectangle diagram) to multiply the binomials $(x+9)(x-4)$.

- 3 51. A square and a rectangle have dimensions as shown below. Determine the expression (in simplest form) that represents the area of the shaded region.

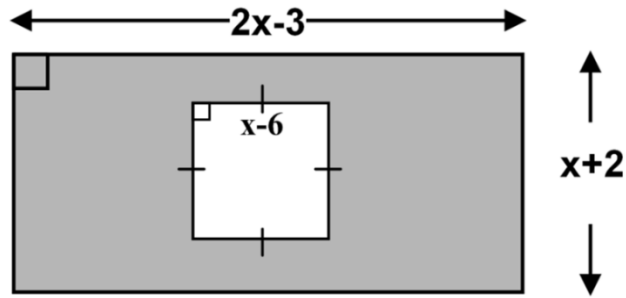

- 4 52. A taxi company charges an initial fee of \$5 plus \$2 for every kilometer driven. Illustrate this relationship using each of the four methods requested in the table below. (Note: d is the distance travelled in km and C is the cost in dollars).

<p>Table of Values:</p> <table border="1" style="margin: 10px auto; border-collapse: collapse;"> <thead> <tr> <th style="width: 50px; text-align: center;">d</th> <th style="width: 50px; text-align: center;">C</th> </tr> </thead> <tbody> <tr><td> </td><td> </td></tr> <tr><td> </td><td> </td></tr> <tr><td> </td><td> </td></tr> <tr><td> </td><td> </td></tr> <tr><td> </td><td> </td></tr> <tr><td> </td><td> </td></tr> <tr><td> </td><td> </td></tr> <tr><td> </td><td> </td></tr> <tr><td> </td><td> </td></tr> <tr><td> </td><td> </td></tr> </tbody> </table>	d	C																					<p>Graph:</p>
d	C																						
<div style="border: 2px solid black; border-radius: 50%; width: 80%; margin: 0 auto; padding: 10px;"> <p style="margin: 0;">Initial fee: \$5.00 Charge per km: \$2.00</p> </div>																							
<p>Equation:</p>	<p>Ordered Pairs:</p>																						

- 4 53. The graph shows Brent leaving home at point A and travelling by truck to a friend's cabin located at point F.

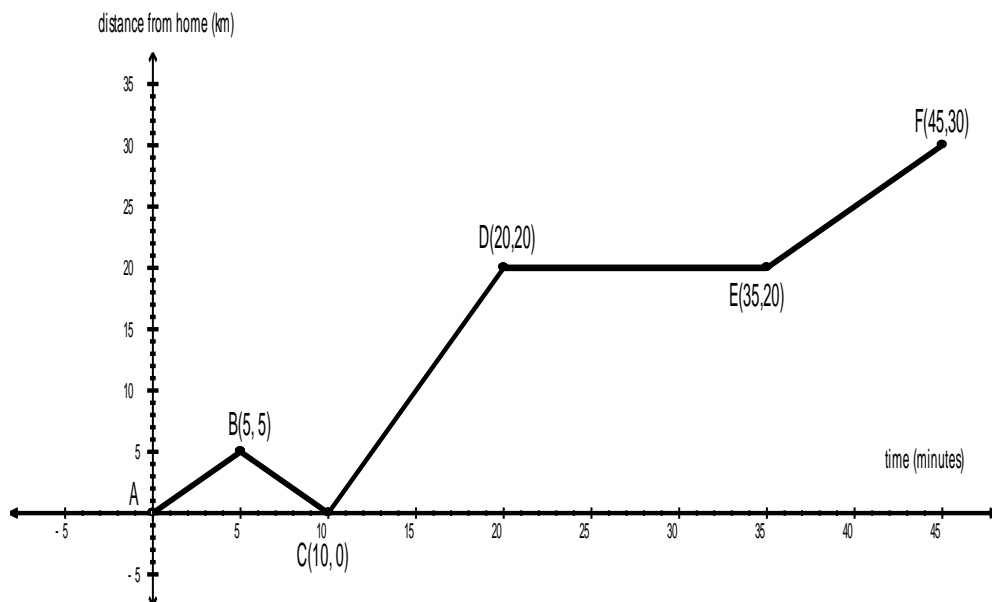

- a) What was his maximum rate of change (*i.e.* speed)?
- b) Brent forgot his compass and had to turn around and go back home. How far was he from home when he had to go back?
- c) Brent stopped to repair a flat tire. How long was he stopped?
- d) How many kilometres did Brent put on the truck from the time he left home (at point A) until he arrived at the cabin?

- 4 54 A line passes through the points (8, -1) and (6, 2). Determine the equation of the line in general form (i.e. $Ax + By + C = 0$).

- 4 55. Determine the equation of the line in slope-intercept form (i.e. $y = mx + b$) that passes through (6, -2) and is parallel to the line $4x - 3y + 12 = 0$.

- 3 56. Solve this system of equations by graphing.

$$\begin{cases} 8x + 5y = 5 \\ 5y - 2x = -45 \end{cases}$$

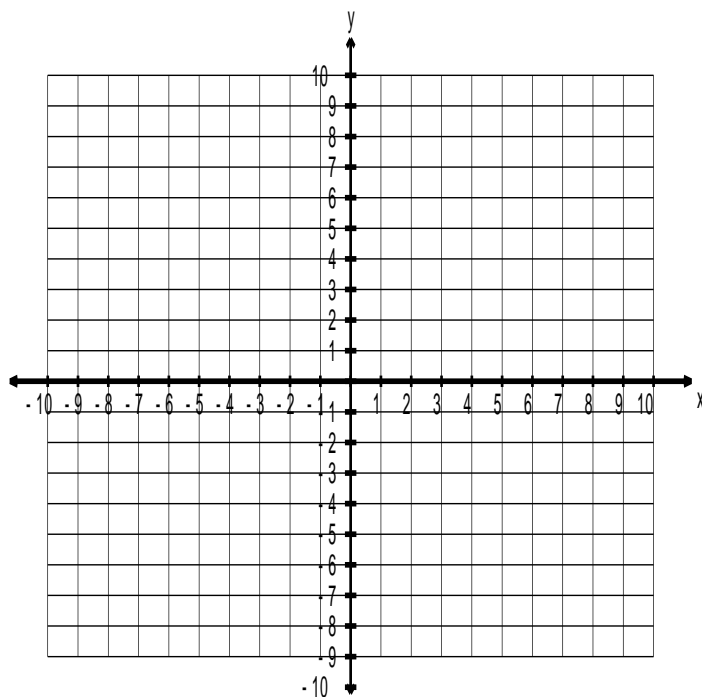

- 3 57. Solve this system of equations using substitution or elimination.

$$\begin{cases} -x + 7y = 35 \\ 12x + 14y = -28 \end{cases}$$

Math 1201 Formulae Sheet

(This sheet may be removed from the exam paper.)

Measurement

Imperial		Imperial to SI Units
1 ft. = 12 in.	 	1 in. = 2.54 cm \doteq 2.5 cm
1 yd. = 3 ft.	 	1 mi. \doteq 1.6 km
1 mi. = 1760 yd.	 	

Surface Area and Volume

Surface Area	Volume
Cylinder $A = 2\pi r^2 + 2\pi rh$	Pyramid $V = \frac{1}{3}[l \times w \times h]$
Cone $A = \pi r^2 + \pi rs$	Cone $V = \frac{1}{3}[\pi r^2 h]$
Sphere $A = 4\pi r^2$	Sphere $V = \frac{4}{3}\pi r^3$