

**DO NOT OPEN THIS EXAMINATION PAPER UNTIL YOU ARE TOLD BY
THE SUPERVISOR TO BEGIN**

Labrador School Board

Mathematics 1201

Final Examination

June 2013

Student Name: _____

Teacher Name: _____

Total Value: 100 marks

Time: 3 Hours

GENERAL INSTRUCTIONS

1. Candidates are required to do all items.
2. The examination has a total of 22 pages (including this cover) consisting of the following parts:

Part I: 40 Multiple Choice Items	Value: 40%
Part II: 18 Constructed Response Questions	Value: 60%
3. **Page 20 is a formulae sheet** to be used for the exam. This page may be removed.
4. Part I should be completed on the answer sheet provided on **Page 21** of the exam. This page may be removed.
5. Answers to the constructed response questions for Part II are to be placed on this paper in the spaces provided.
6. For Part II items, candidates are reminded to show ALL necessary steps and calculations. Partial credit may be awarded for logical work even though you might not arrive at the correct solution. Correct answers without appropriate calculations will not merit full marks.
7. A self powered calculator may be used for calculations and to obtain special values. Graphing calculators are to be reset before the examination begins.

REGULATIONS FOR CANDIDATES

Candidates are expected to be thoroughly familiar with all regulations pertaining to their conduct during examinations. Candidates must comply with all requirements governing the following matters.

- Materials required
- Leaving the room
- Materials not permitted
- Models of calculators permitted
- Use of pen or pencil
- Use of unauthorized means and penalties
- Completion of required information
- Communication during the exam

Part I
Total Value: 40%

1. Which is a good referent for 1 inch?
 - A) distance from a doorknob to the floor
 - B) thickness of a dime
 - C) thickness of a hockey puck
 - D) width of your hand

2. Which Imperial unit is best for measuring the length of a hockey rink?
 - A) kilometres
 - B) metres
 - C) miles
 - D) yards

3. The length of a table is 3 metres. What is the approximate length in inches?
 - A) 75
 - B) 120
 - C) 750
 - D) 1200

4. A cone has a diameter of 12.4 cm and a slant height of 9.3 cm. What is the surface area to the nearest cm^2 ?
 - A) 201
 - B) 220
 - C) 302
 - D) 845

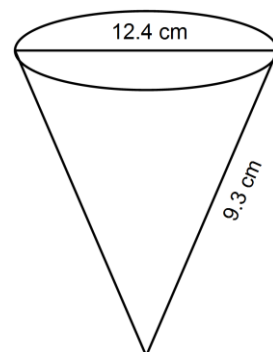

5. A square-based pyramid has side length 3.2 ft. and a height of 4.5 ft. What is the volume to the nearest ft.^3 ?
 - A) 5
 - B) 15
 - C) 19
 - D) 46

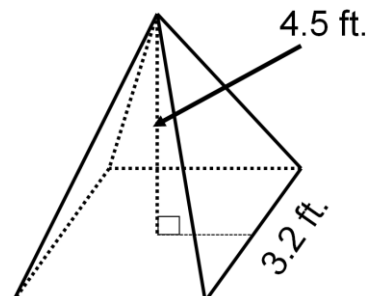

6. Which ratio represents $\tan \angle A$?

- A) $\frac{7}{25}$
- B) $\frac{24}{25}$
- C) $\frac{25}{24}$
- D) $\frac{24}{7}$

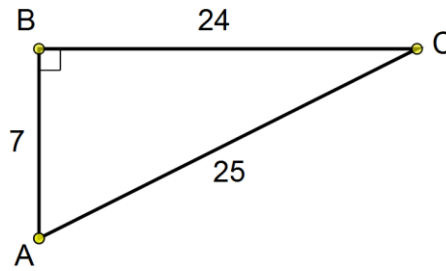

7. In $\triangle DOG$, what is the length of the hypotenuse to the nearest tenth of an inch?

- A) 5.7
- B) 11.1
- C) 14.0
- D) 27.5

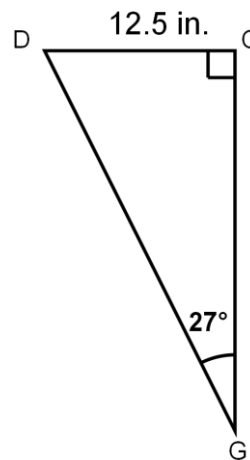

8. A firefighter rests a 15.6 m ladder against a building. The ladder is 8.5 m from the base of the building. What angle does the ladder make with the ground, to the nearest degree?

- A) 29°
- B) 33°
- C) 57°
- D) 61°

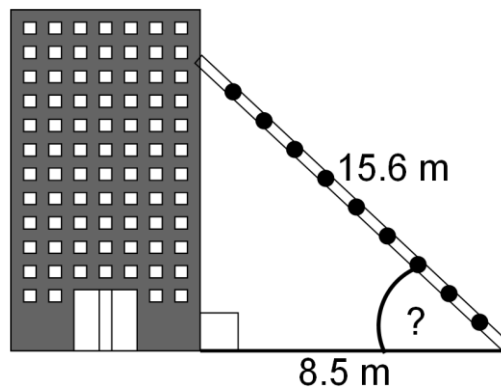

9. A 1.7 m tall forest ranger is 9.5 m from the base of a tree. The angle of inclination from her eye level to the top of the tree is 37°. What is the approximate height of the tree to the nearest tenth of metre?

- A) 7.2
- B) 7.4
- C) 8.9
- D) 9.3

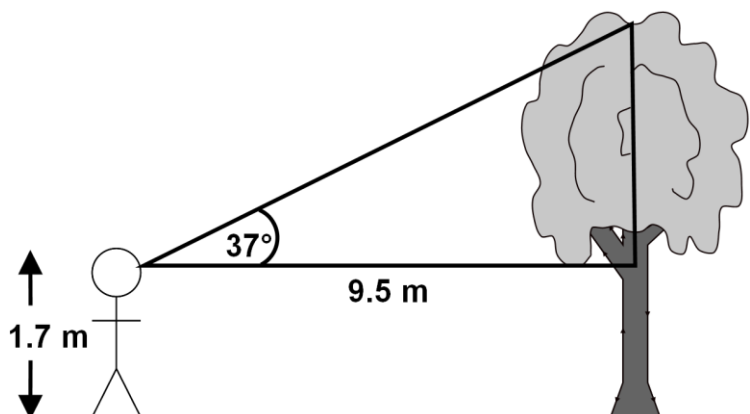

10. What are the prime factors of 120 ?
- A) 2, 3, 5
 - B) 2^3 , 3, 5
 - C) 10, 20, 30, 40, 60, 120
 - D) 1, 2, 3, 4, 5, 6, 8, 10, 12, 15, 20, 24, 30, 40, 60, 120

11. What is the exact value of $\sqrt[3]{\frac{8}{27}}$?

- A) $\frac{2}{9}$
- B) $\frac{24}{81}$
- C) $\frac{4}{9}$
- D) $\frac{2}{3}$

12. Which is irrational?

- A) $\sqrt{0.36}$
- B) $\sqrt{\frac{16}{25}}$
- C) $\sqrt[3]{49}$
- D) $\sqrt[3]{64}$

13. What is $6^{-\frac{2}{3}}$ expressed as a radical?

- A) $-\sqrt{6^3}$
- B) $-\sqrt[3]{6^2}$
- C) $\frac{1}{\sqrt{6^3}}$
- D) $\frac{1}{\sqrt[3]{6^2}}$

14. What is the least common multiple of 252 and 600?

- A) 36
- B) 210
- C) 2100
- D) 12600

15. What is the correct order, from **least** to **greatest**, of these mixed radicals?

$$2\sqrt{3}, 3\sqrt{2}, 2\sqrt[3]{-3}, 3\sqrt[3]{2}$$

A) $2\sqrt[3]{-3}, 2\sqrt{3}, 3\sqrt[3]{2}, 3\sqrt{2}$

B) $2\sqrt[3]{-3}, 2\sqrt{3}, 3\sqrt{2}, 3\sqrt[3]{2}$

C) $3\sqrt{2}, 3\sqrt[3]{2}, 2\sqrt{3}, 2\sqrt[3]{-3}$

D) $3\sqrt[3]{2}, 3\sqrt{2}, 2\sqrt{3}, 2\sqrt[3]{-3}$

16. What is $\sqrt{80}$ as a mixed radical in simplest form?

A) $2\sqrt{20}$

B) $4\sqrt{5}$

C) $5\sqrt{4}$

D) $16\sqrt{5}$

17. Simplify: $\frac{18x^3y^2}{6x^4y}$

A) $\frac{3y}{x}$

B) $3xy$

C) $\frac{12y}{x}$

D) $12xy$

18. Which multiplication is represented by the algebra tiles? (Note: Shaded tiles are positive.)

A) $(2x^2 + 2)(x^2 - 3)$

B) $(2x - 2)(x + 3)$

C) $(2x^2 - 2)(x^2 + 3)$

D) $(2x + 2)(x - 3)$

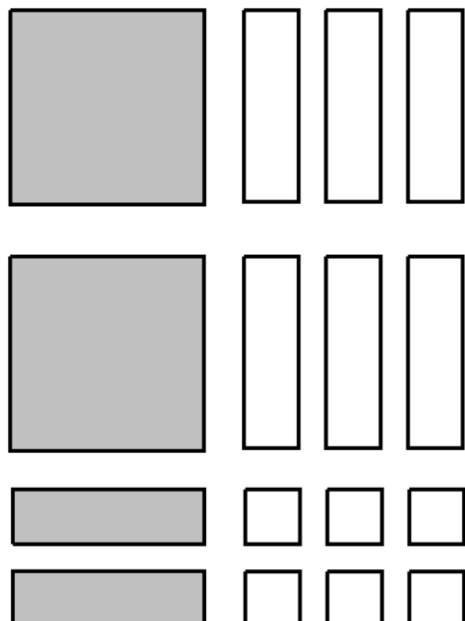

19. Factor completely: $24ab^2 - 16a^2b^2$

A) $ab^2(24 - 16a)$

B) $4ab(b - 4ab)$

C) $8(3ab^2 - 2a^2b^2)$

D) $8ab^2(3 - 2a)$

20. Expand and simplify: $(6x + 7)(5 - x)$

A) $-6x^2 - 37x + 35$

B) $-6x^2 - 23x + 35$

C) $-6x^2 + 23x + 35$

D) $-6x^2 + 37x + 35$

21. Which model represents $(x + 5)(x - 2)$?

A)

	x	$-$	2
x	x^2		$-2x$
+			
5	$5x$		-10

B)

	x	$-$	2
x	x^2		$2x$
+			
5	$5x$		10

C)

	x	$-$	2
x	$2x$		$-2x$
+			
5	$5x$		-10

D)

	x	$-$	2
x	$2x$		$-2x$
+			
5	$5x$		3

22. Which trinomial has $(x - 3)$ as a factor?

A) $x^2 - 5x - 6$

B) $x^2 - x - 6$

C) $x^2 + x - 6$

D) $x^2 + 5x - 6$

23. Factor: $2a^2 + 11a + 12$

A) $(2a + 3)(a + 4)$

B) $(2a + 4)(a + 3)$

C) $(2a + 6)(a + 4)$

D) $(2a + 8)(a + 3)$

24. Factor: $25x^2 - 36y^2$

A) $(5x - 6y)(5x - 6y)$

B) $(5x - 6y)(5x + 6y)$

C) $(5x + 6y)(5x + 6y)$

D) $(6y + 5x)(6y - 5x)$

25. What is $f(2)$ for the function $f(x) = -4x - 9$?

A) -17

B) -1

C) 1

D) 17

26. Which equation does **NOT** represent a linear relation?

A) $x = 10$

B) $4x + 5y = 20$

C) $y = -5x + 4$

D) $y = x^2 + 5$

27. Which arrow diagram represents a function?

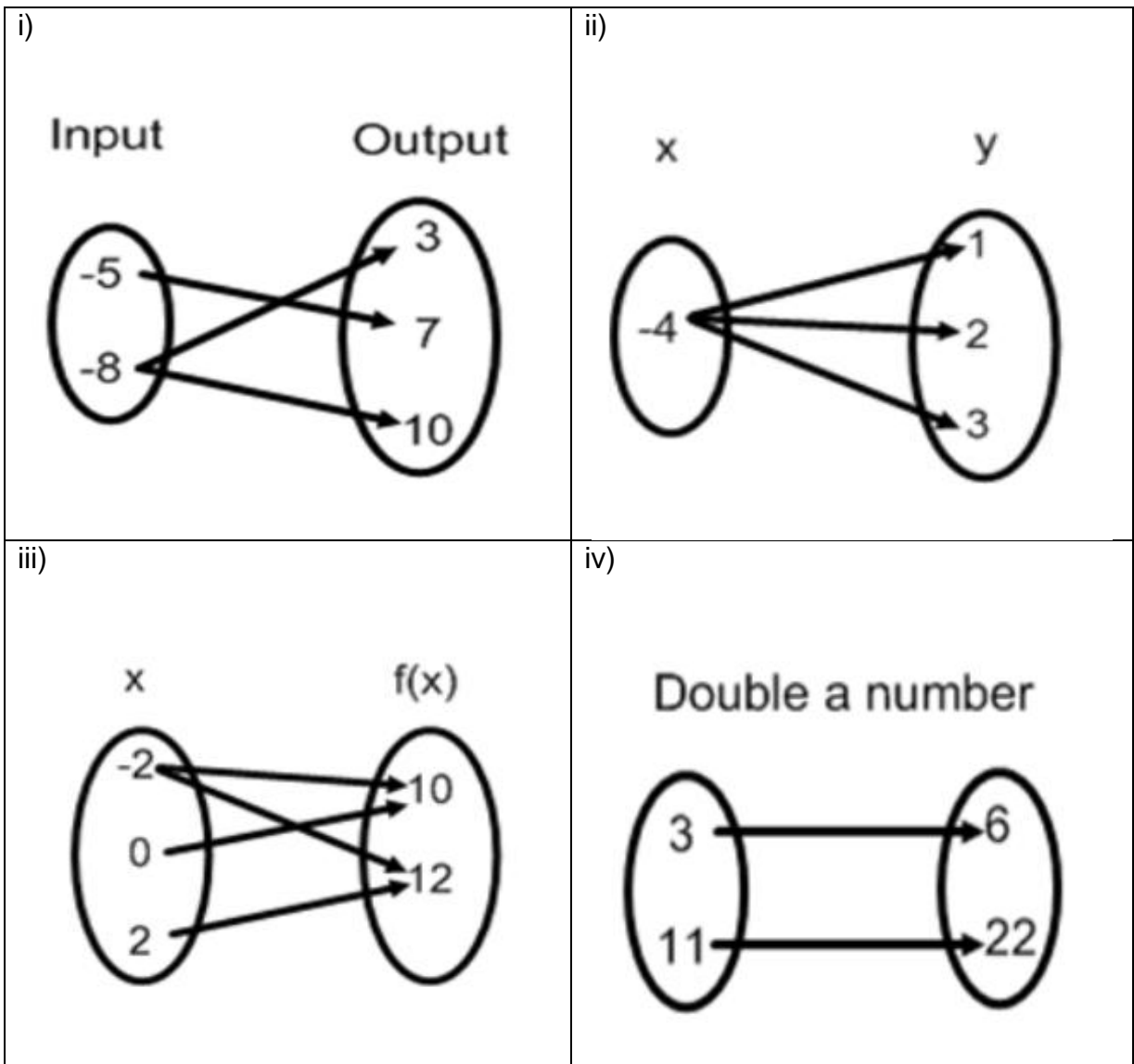

- A) i
- B) ii
- C) iii
- D) iv

28. What is the range of the graph?

- A) $[-5, 5]$
- B) $(-5, 5)$
- C) $[-3, 3]$
- D) $(-3, 3)$

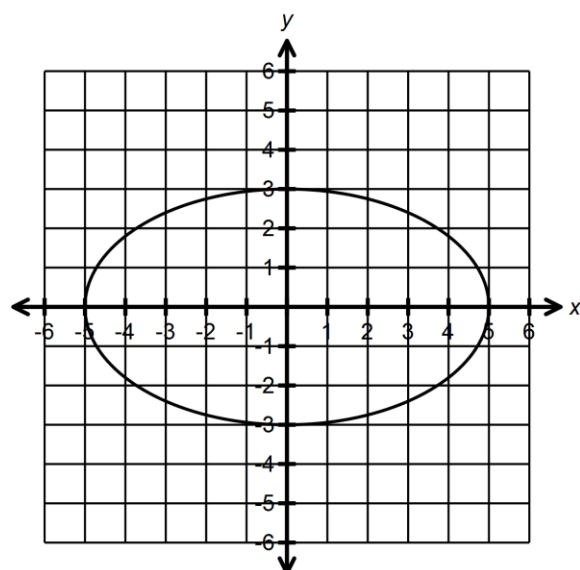

29. Which table of values represents a linear function?

A)

x	0	1	2	3	4
y	2	6	10	14	18

B)

x	0	1	2	3	4
y	4	7	12	19	28

C)

x	0	1	2	3	4
y	4	8	16	32	64

D)

x	0	1	2	3	4
y	25	24	22	19	15

30. Each graph shows distance, d metres, as a function of time, t hours. Which graph has a rate of change of 3 m/h and a vertical intercept of 2 m?

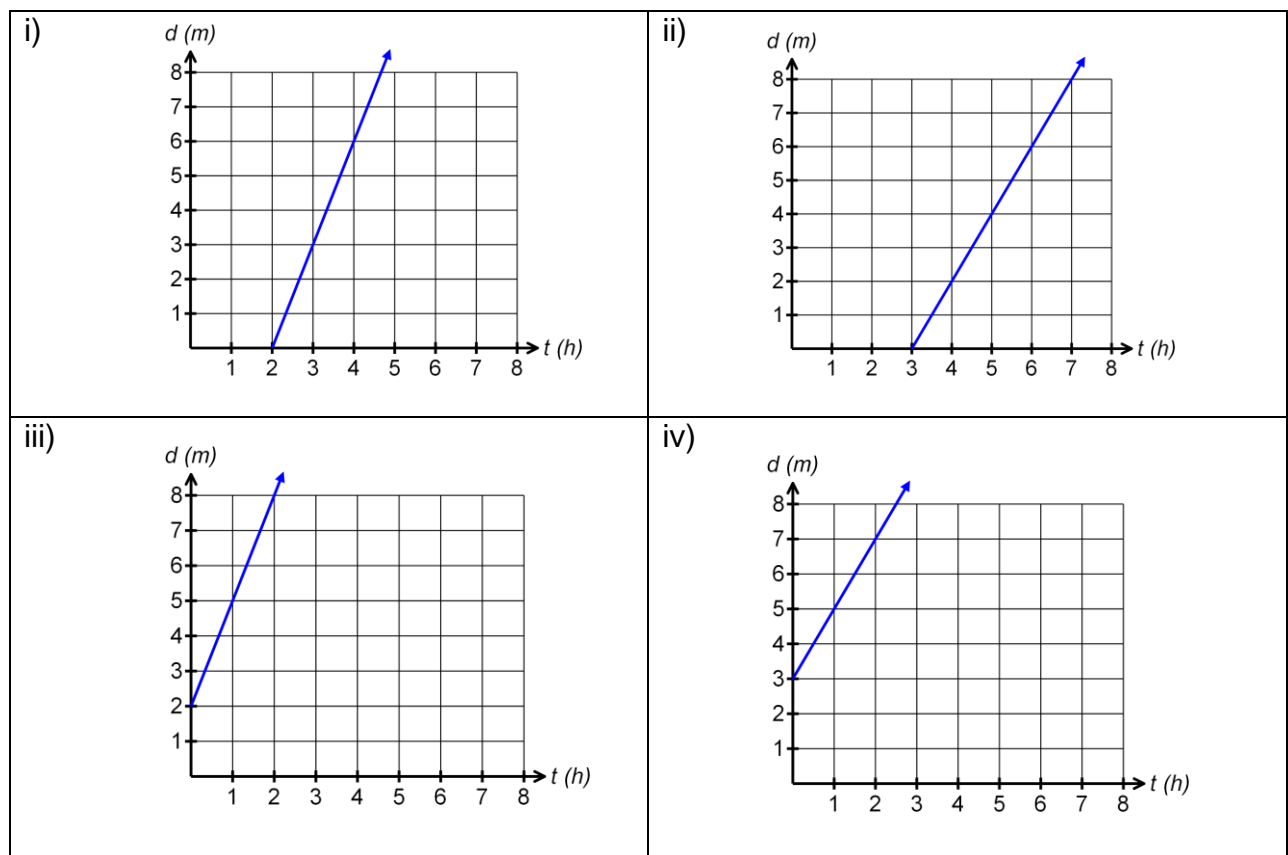

A) i

B) ii

C) iii

D) iv

31. Which line has a positive slope?

- A) A
- B) B
- C) C
- D) D

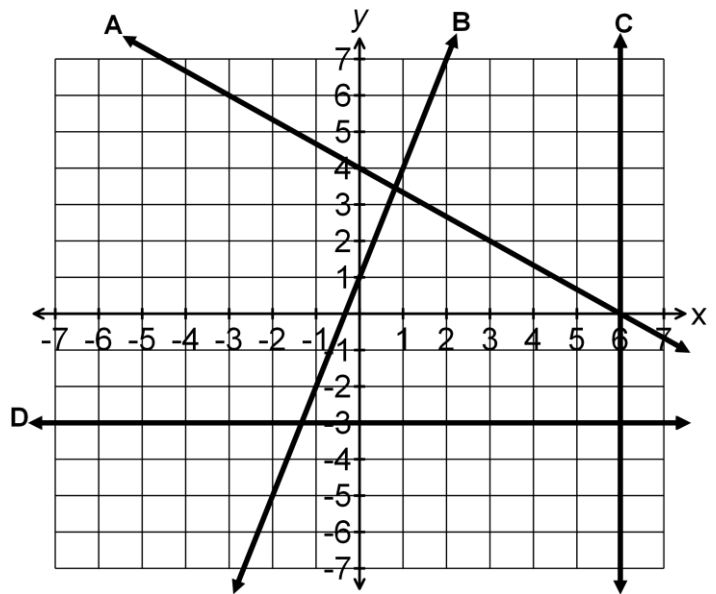

32. What is the slope of the line?

- A) $-\frac{5}{2}$
- B) $-\frac{2}{5}$
- C) $\frac{2}{5}$
- D) $\frac{5}{2}$

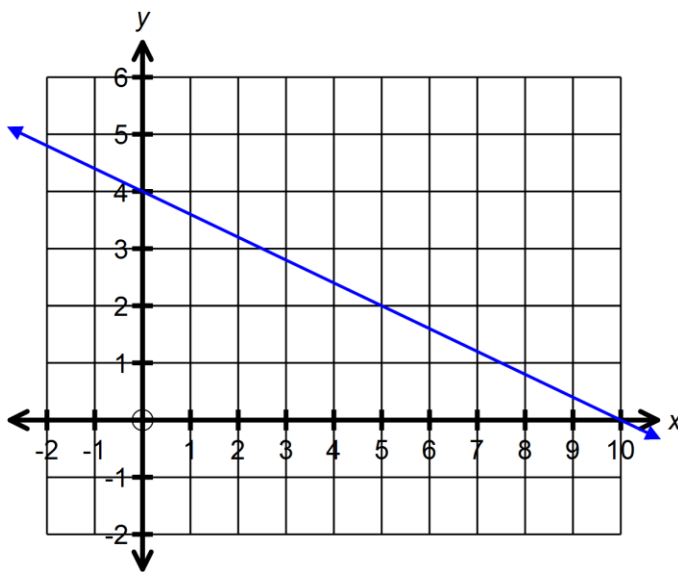

33. A line has a slope of 2 and passes through the point $(-2, 5)$. What is its equation in slope-point form?

- A) $y - 5 = 2(x + 2)$
- B) $y - 5 = 2(x - 2)$
- C) $y + 5 = 2(x + 2)$
- D) $y + 5 = 2(x - 2)$

34. Which graph represents the linear relation $y = \frac{1}{2}x - 4$?

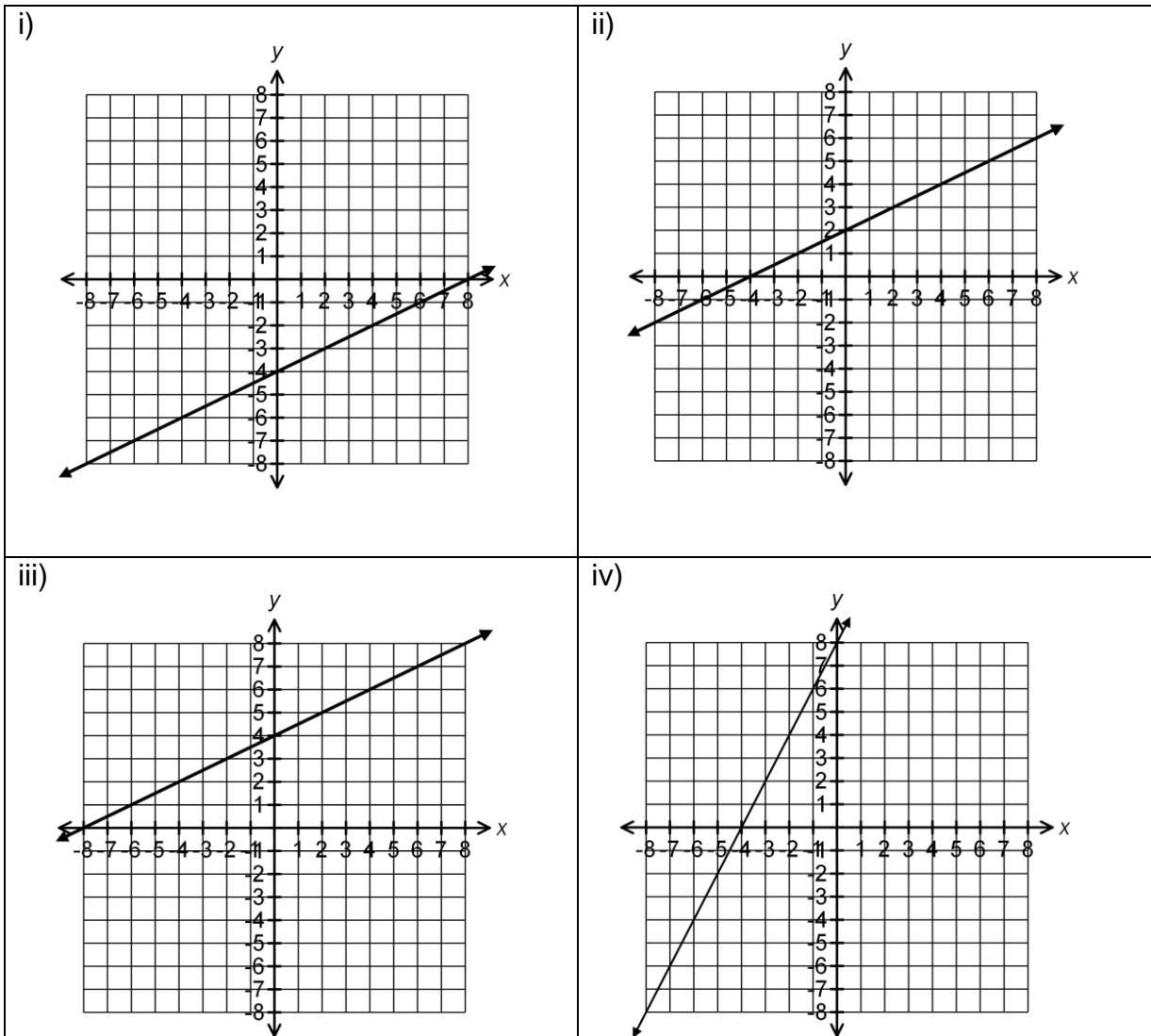

- A) i
- B) ii
- E) iii
- D) iv

35. The local ski club offers lessons at a cost of \$20 for every 20 minutes of instruction. What is the rate of change per hour?

- A) \$20
- B) \$40
- C) \$60
- D) \$80

36. What is the general form of $y - 3 = -4(x + 2)$?

- A) $-4x + y - 11 = 0$
- B) $-x + y - 1 = 0$
- C) $4x + y - 5 = 0$
- D) $4x + y + 5 = 0$

37. Solve: $\begin{cases} x = 4 \\ 2x + y = 10 \end{cases}$

A) $(4, -14)$

B) $(4, -2)$

C) $(4, 2)$

D) $(4, 18)$

38. How many solutions exist for the system $\begin{cases} y = \frac{3}{4}x - 3 \\ y = \frac{3}{4}x - 4 \end{cases}$?

A) infinite

B) none

C) one

D) two

39. Solve: $\begin{cases} y = -2x + 4 \\ y = x - 2 \end{cases}$

A) $(-4, -2)$

B) $(-2, -4)$

C) $(0, 2)$

D) $(2, 0)$

40. 250 people attended a school concert. Student tickets cost \$3 and adult tickets cost \$5. The amount collected was \$950. Which system models this situation?

x represents the number of student tickets sold

y represents the number of adult tickets sold

A) $\begin{cases} x + y = 250 \\ 3x + 5y = 950 \end{cases}$

B) $\begin{cases} x + y = 250 \\ 5x + 3y = 950 \end{cases}$

C) $\begin{cases} x + y = 950 \\ 3x + 5y = 250 \end{cases}$

D) $\begin{cases} x + y = 950 \\ 5x + 3y = 250 \end{cases}$

Part II
Total Value: 60%

value
3

41. A right square pyramid has side length 36 cm and slant height 30 cm. What is the volume of the pyramid to the nearest cm^3 .

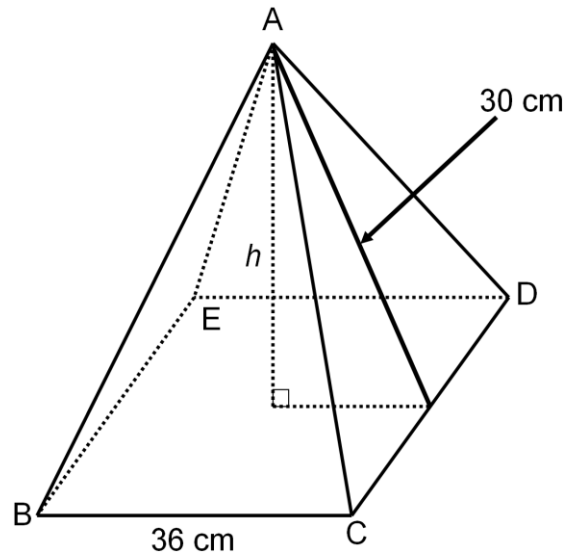

- 2 42. The surface area of a sphere is 804.2 in.^2 . What is the radius of the sphere?

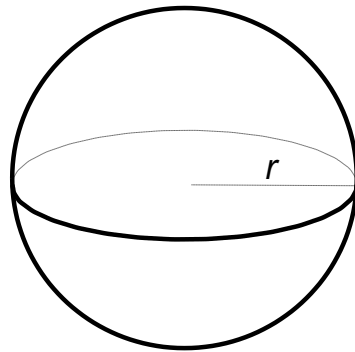

- 4 43. Joe made a wooden scratching post for his cat and wants to cover it with carpet. About how much carpet will he need if he covers everything except the bottom of the square block?

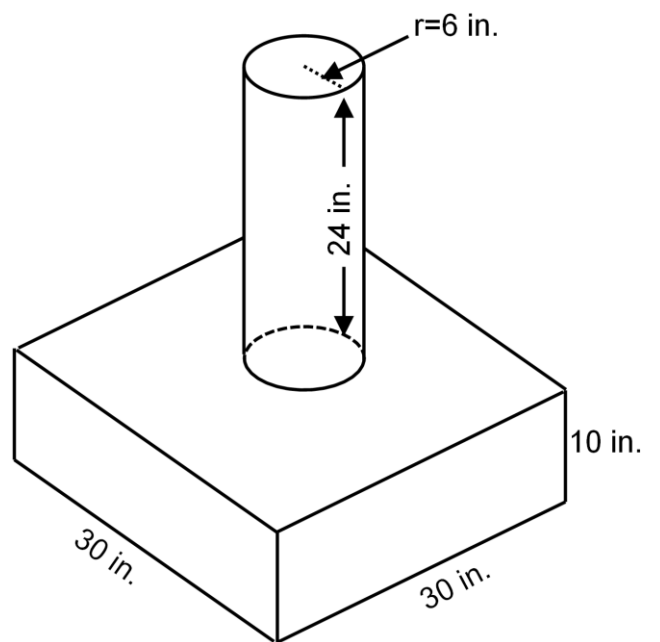

- 4 44. Solve $\triangle CAT$. Give all measurements to the nearest tenth.

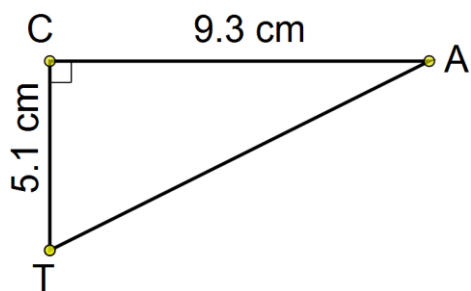

- 4 45. At 180 m from shore, some tourists spot a lighthouse from their boat. The angle of elevation to the bottom of the lighthouse is 26° . The angle of elevation to the top of the lighthouse is 36° . What is the height, h , of the lighthouse?

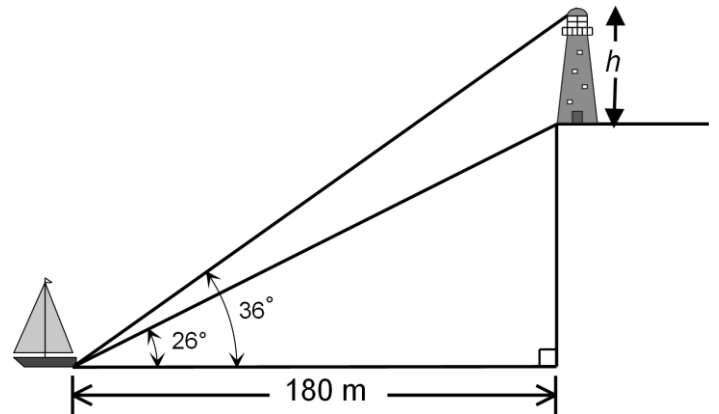

- 3 46. Julie completed a math problem and made a mistake. In which step does the first error occur? Rewrite Julie's solution so that it is correct.

The error occurs in step _____

Correct solution:

$$\frac{(4a^{-3}b^4)^{-2}}{a^6b^{-1}}$$

$$\text{Step 1} = \frac{4^{-2}a^6b^{-8}}{a^6b^{-1}}$$

$$\text{Step 2} = \frac{a^0b^{-9}}{4^2}$$

$$\text{Step 3} = \frac{1}{16b^9}$$

- 3 47. Simplify: (the final answer must contain only positive exponents)

$$\left(\frac{x^6 y^{-\frac{1}{3}}}{125x^{-9} y^{\frac{8}{3}}} \right)^{-\frac{1}{3}}$$

- 4 48. The surface area of a cube is 96 cm^2 . Determine the length of the diagonal, x , of one of the faces. Express your answer in simplest radical form.

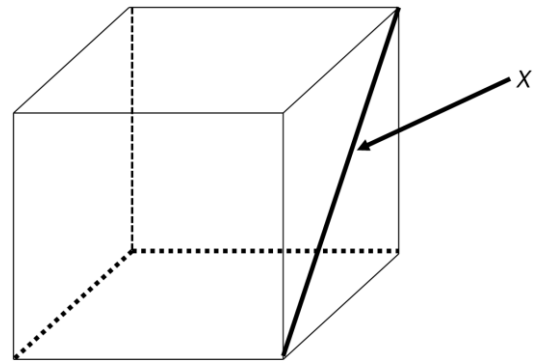

- 3 49. Expand and simplify: $(2x - 7)(3x^2 + 4x + 2)$

- 3 50. Factor completely: $4x^3 + 6x^2 - 4x$

- 3 51. The area of a rectangle is represented by the polynomial $8x^2 + 10x + 3$. If the length of one side is $4x + 3$, determine the width of the rectangle.

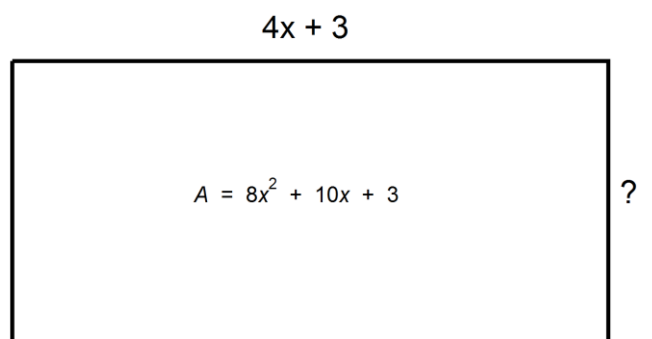

- 4 52. Valerie plans to put siding on the front of her garage pictured below. Find an expression (in simplest form) to represent the area of the surface to be covered with siding. (Note: There will be **NO** siding on the two doors.)

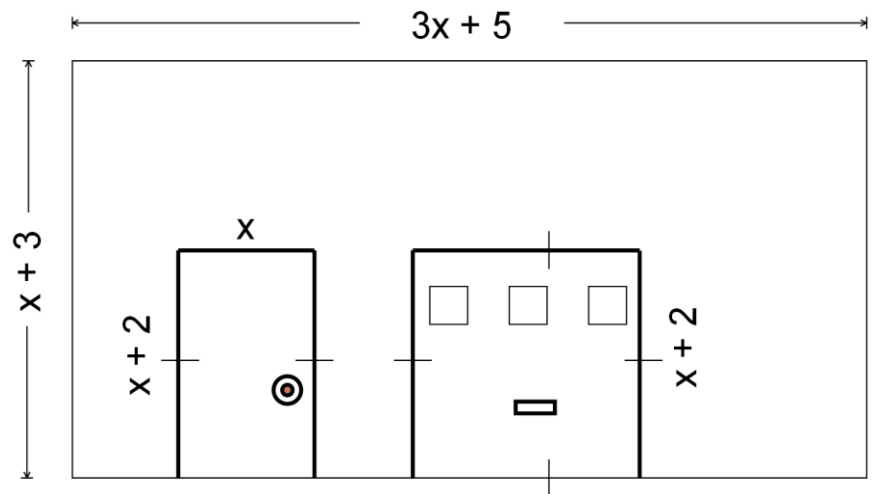

- 4 53. A t-shirt printing company charges \$20 for the initial setup of the printing press plus \$5 for every t-shirt printed. Illustrate this relationship using each of the four methods requested in the table below. (Note: n is the number of t-shirts and C is the cost in dollars.)

<p>Table of Values:</p> <table border="1" style="margin-left: auto; margin-right: auto; text-align: center;"> <thead> <tr> <th style="padding: 2px 10px;">n</th> <th style="padding: 2px 10px;">C</th> </tr> </thead> <tbody> <tr><td> </td><td> </td></tr> <tr><td> </td><td> </td></tr> <tr><td> </td><td> </td></tr> <tr><td> </td><td> </td></tr> <tr><td> </td><td> </td></tr> <tr><td> </td><td> </td></tr> <tr><td> </td><td> </td></tr> <tr><td> </td><td> </td></tr> <tr><td> </td><td> </td></tr> <tr><td> </td><td> </td></tr> </tbody> </table>	n	C																					<p>Graph:</p>
n	C																						
<div style="border: 2px solid black; border-radius: 50%; padding: 10px; display: inline-block;"> <p>Initial fee: \$20.00 Charge per km: \$5.00</p> </div>																							
<p>Equation:</p>	<p>Ordered Pairs:</p>																						

- 3 54. The graph shows Jake leaving home at Point A and travelling by motorcycle to Gros Morne, located at point H.

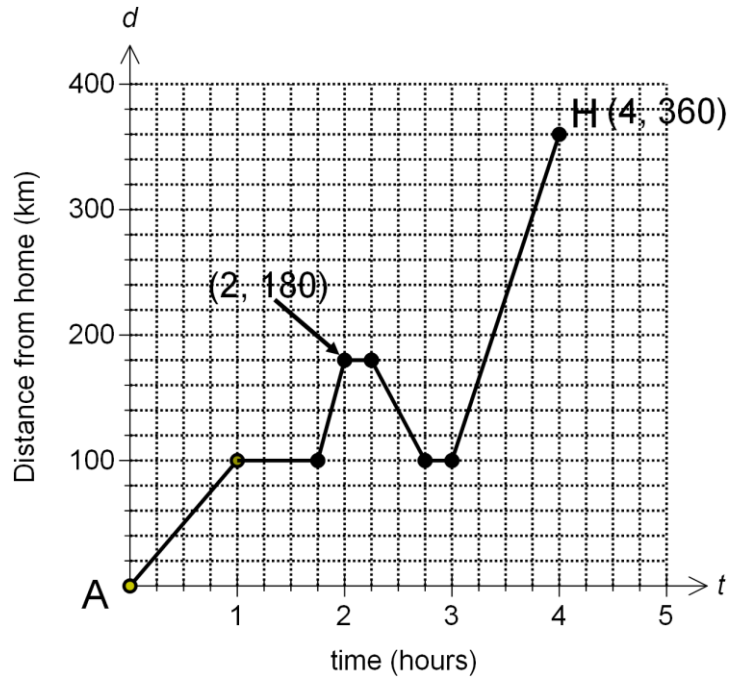

A) What was Jake's maximum rate of change (i.e. speed)?

B) From the time he left home, how many times did Jake stop and what was the total minutes stopped?

Jake stopped _____ times

He was stopped for a total of _____ minutes

C) How many kilometres did Jake put on his motorcycle from the time he left home (at point A) until he arrived at Gros Morne (point H)?

- 3 55. A line passes through the points $(6, 4)$ and $(2, -6)$. Determine the equation of the line in slope-intercept form ($y = mx + b$).

- 4 56. Determine the equation of the line that passes through $(10, -4)$ and is perpendicular to the line $7x - 14y + 28 = 0$.

3 57. Solve graphically:

$$\begin{cases} y - 1 = -\frac{1}{2}(x - 2) \\ y = \frac{1}{2}x + 4 \end{cases}$$

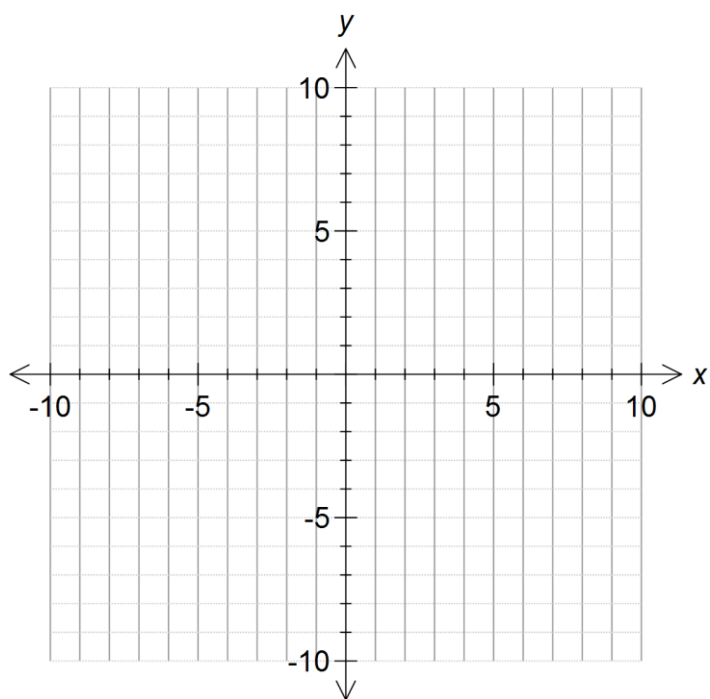

- 3 58. At a music store, all CDs are the same price and all DVDs are the same price. Andrew buys 6 CDs and 8 DVDs for a total of \$126. Jane buys 1 CD and 4 DVDs for a total of \$53. Write a linear system and solve the system **algebraically** to determine the price of one CD and one DVD.

Math 1201 Formulae Sheet

(This sheet may be removed from the exam paper.)

Measurement

Imperial		Imperial to SI Units
1 ft. = 12 in.	 	1 in. = 2.54 cm \doteq 2.5 cm
1 yd. = 3 ft.	 	1 mi. \doteq 1.6 km
1 mi. = 1760 yd.	 	

Surface Area and Volume

Surface Area	Volume
Cylinder $A = 2\pi r^2 + 2\pi rh$	Pyramid $V = \frac{1}{3}[l \times w \times h]$
Cone $A = \pi r^2 + \pi rs$	Cone $V = \frac{1}{3}[\pi r^2 h]$
Sphere $A = 4\pi r^2$	Sphere $V = \frac{4}{3}\pi r^3$

Math 1201 Multiple Choice Answer Sheet

(This sheet may be removed from the exam paper.)

Teacher: _____

Name: _____

1.
2.
3.
4.
5.
6.
7.
8.
9.
10.
11.
12.
13.
14.
15.
16.
17.
18.
19.
20.

21.
22.
23.
24.
25.
26.
27.
28.
29.
30.
31.
32.
33.
34.
35.
36.
37.
38.
39.
40.